

XC-GL Series

Elevator Control Board

User Manual

Version 2.0

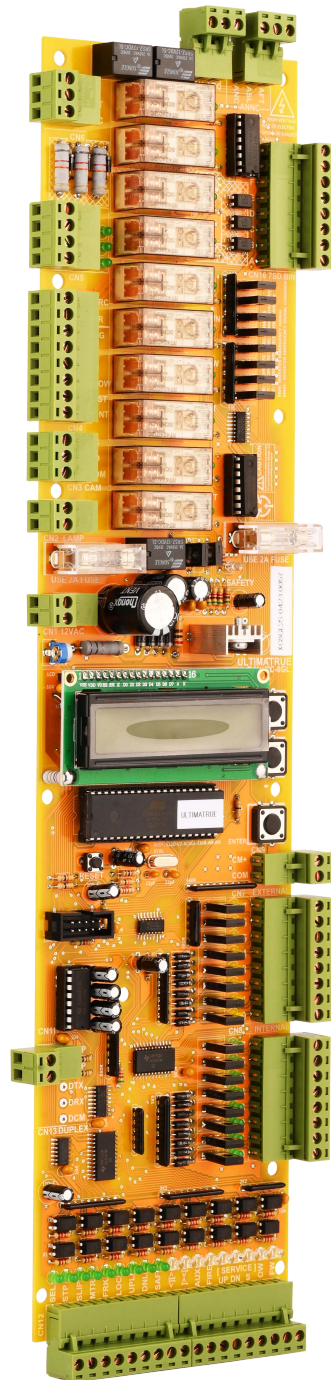

Table of Contents:

1.0	General Description	05
1.1	Table of Locations	06
1.2	Safety Precautions	08
1.2.1	Transport and Inspection	08
1.2.2	Storage	08
1.2.3	Warnings and Hazards	09
2.0	Technical Specifications	10
2.1	Product Description	10
2.2	Basic Settings	12
3.0	Installation and Connections.....	13
3.1	Car and Shaft	13
3.1.1	SEL.....	15
3.1.2	STP.....	15
3.1.3	SLIP.....	16
3.1.4	MTR.....	16
3.1.5	FRK.....	17
3.1.6	LOC.....	17
3.1.7	UPL.....	17
3.1.8	DNL	17
3.1.9	SAF.....	18
3.1.10	<][>.....	18
3.1.11]<>[.....	18
3.1.12	AUX	19
3.1.13	FIRE	20
3.1.14	SERVICE.....	20

3.1.15	OW.....	21
3.1.16	FW.....	21
3.2	Serial Indicator (XD-S).....	23
3.3	7-Segment Indicator.....	25
3.4	Floor Wire Indicator	26
3.5	Car and Landing Calls	28
3.6	Arrow Signals.....	30
3.7	Gong Signals	31
3.8	Manual Doors	32
3.9	Three-Phase Automatic Doors	33
3.10	Single-Phase Automatic Doors	34
3.11	Single-Phase Semi-Automatic Doors.....	35
3.12	Inverter Motion Signals and Power Supply	36
3.13	Safety Circuits.....	38
3.14	Magnetic Configuration	40
3.15	Car.....	42
4.0	Basic Programming	43
4.1	Program P1: Floor Number.....	45
4.2	Program P2: Display Mode	46
4.3	Program P3: LED Matrix (XD-S).....	48
4.4	Program P4: Door Type.....	50
4.5	Program P5: System Type	51
4.6	Program P6: Collective	52
4.7	Program P7: Wait Time	53
4.8	Program P8: CAM Time	54
4.9	Program P9: Slow Time.....	55
4.10	Program P10: Fast Time.....	56
4.11	Program P11: Lamp Time	58
4.12	Program P12: Emergency.....	59
4.13	Program P13: Keycode.....	61

5.0	Advanced Programming	62
5.1	Program P14: CAM Trials	64
5.2	Program P15: Fork Time	65
5.3	Program P16: Park Time	66
5.4	Program P17: Operation Timeout	67
5.5	Program P18: Service Telephone	69
5.6	Program P19: Set Password.....	70
5.7	Program P20: Active Floor	71
5.8	Program P21: Lock Error	73
5.9	Program P22: Max Calls	74
5.10	Program P23: Fire Man	75
5.11	Program P24: Factory Set.....	77
5.12	Program P25: Restore Selector.....	78
5.13	Program P26: Service Control (Inspection Mode)	79
6.0	Additional Programming	80
6.1	Binary Indicator (XD-B)	80
7.0	Malfunction Diagnosis	81
7.1	LCD Board Screen	81
7.2	7-Segment Indicator.....	82
7.3	Serial Indicator (XD-S)	83
8.0	Disclaimer	84
9.0	Warranty	85
	Index	86

List of Tables and Figures:

Table 1.0 - Table of Locations.....	06
Table 2.0 - Warnings and Hazards	09
Table 3.0 - Product Description	10
Table 4.0 - Model Description.....	11
Table 5.0 - Basic Settings	12
Table 9.0 - Serial Indicator Error View	83
Table 8.0 - 7-Segment Indicator Error View.....	82
Table 7.0 - LCD Board Screen Error View	81
Table 6.0 - Binary Indicator (XD-B) Programming.....	80
Figure 1.0 - Board Layout	07
Figure 2.0 - Car and Shaft Connections	14
Figure 2.1 - Weight Signal Connections	22
Figure 3.0 - Serial Indicator Connections	24
Figure 4.0 - 7-Segment Indicator Connections.....	25
Figure 5.0 - Floor Wire Indicator Connections.....	27
Figure 6.0 - Car and Landing Call Connections	29
Figure 7.0 - Arrow Signals Connections	30
Figure 8.0 - Gong Signal Connections	31
Figure 9.0 - Manual Door Connections	32
Figure 10.0 - Three-Phase Automatic Door Connections.....	33
Figure 11.0 - Single-Phase Automatic Door Connections	34
Figure 12.0 - Single-Phase Semi-Automatic Door Connections	35
Figure 13.0 - Inverter Motion Signals and Power Supply Connections	37
Figure 14.0 - Safety Circuit Connections	39
Figure 15.0 - Magnetic Configuration	41
Figure 16.0 - Car Connections	42
Figure 17.0 - Programming Guide Layout	43

1.0 General Description

The XC-GL series is an elevator control board series that is fully designed and manufactured at Ultimatrue Engineering Industries. The XC-GL series user manual operates to serve multiple elevator control board models, which include: XC-8GL/2S, XC-8GL/3S, XC-16GL/2S, XC-16GL/3S, XC-GL2S/SC, XC-GL83S/SC. The XC-GL series operates up to eight stops, with additional features to satisfy customer specifications. The XC-GL series supports extensions up to sixteen stops using the XE-1 extension board and all types of brand indicators (XDP-2W & XD-2W, XD-B, and XD-S). The XC-GL series operate using only the gearless motor, door types (manual, wait-open automatic and wait-close automatic), and various elevator call collections, such as: down-collective, simple-collective, and A.P.B (single-call). The XC-GL series contain safety circuits by hardware and by software designed to control speed and direction systems to halt operations if any failures occur in the fork, lock, slip, stop, etc. In addition to an internal phase failure system. The XC-GL series provides a total of twenty-six software programs, distributed across basic and advanced programming functionalities, accustomed with a user-friendly menu interface. The XC-GL series also provides built-in fault and error diagnosis information that could be viewed on the LCD board screen, 7-segment indicator, and serial indicator (XD-S).

The XC-GL series complies with the international lift safety standards EN 81-20 and EN 81-50.

Ultimatrue Engineering Industries is a certified ISO 9001:2015 and ISO 45001:2018 company.

1.1 Table of Locations

Pointer	Function
1	Controller power supply
2	Car light signals
3	Automatic door and retiring CAM signal
4	Motor speeds - Direction signals
5	Emergency signal
6	Three-phase and neutral
7	Inverter power supply
8	Car calls
9	Landing calls
10	Shaft common (CM+) and Calls common (COM)
11	Indicator outputs: 7-segment, binary, floor-wire
12	Serial indicator
13	Shaft connection signals
14	Inspection signals
15	Weight signals
16	Duplex socket
17	Arrow signals
18	Gong signals
19	XE-1 connection socket

Table 1.0 - Table of Locations

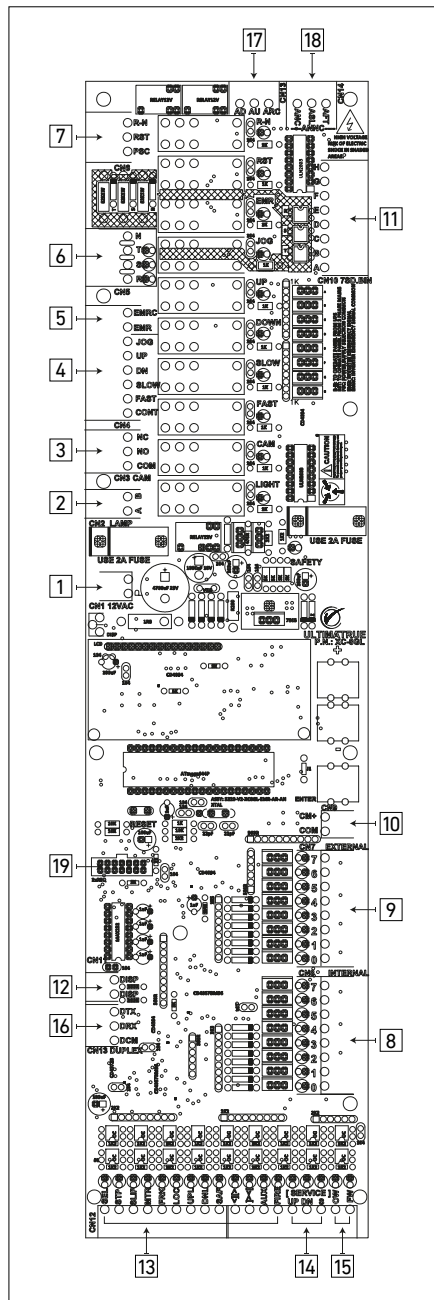

Figure 1.0 - Board Layout

Note:

Please head over to the Installation and Wiring section for more information on the individual inputs/outputs.

1.2 Safety Precautions

To fully benefit from using the XC-GL series please read the user manual carefully before installation and initiating operation. Keep it nearby for future reference whenever necessary.

1.2.1 Transport and Inspection

The units are delivered from the factory ready for installation.

Upon receiving the XC-GL series' units please check that the delivered equipment has not been damaged during transport. If any such damage occurs, a claim must be submitted to the carrier immediately.

After unpacking, the following must be checked:

- The XC-GL series is not damaged.
- The XC-GL series package is sealed.

1.2.2 Storage

The XC-GL series board must be stored under cover in a dry and well-ventilated area until it's installed and ready for operation.

1.2.3 Warnings and Hazards

Before initiating operations, make sure that all connections, wirings, and board connectors are connected properly.





Warnings and Hazards	
	Never touch the phases outlet (CN5) on the XC-GL series to avoid electric shock hazards.
	Never install the XC-GL series in places subject to rain, direct sunlight, or places with a degree of high dust.
	The main power terminals must be kept away from the indicator and call terminals.
	Electricity must be turned OFF during the removal or the installation of the XC-GL series board.

Table 2.0 - Warnings and Hazards

2.0 Technical Specifications

2.1 Product Description

Technical Specifications	Description
Board Dimensions	10 cm * 40 cm
Maximum Current Consumption	1 A
Protection Fuses	Two Fuses (2 A) for supply input and shaft supply as protection
Operating Temperature	10° C - 45° C
Storage Temperature	10° C - 60° C
Motor Types	Gearless
Drive Types	Inverters
Car Speed	Two-speed models: Up to 1 m/s
	Three-speed models: Up to 1.6 m/s
Door Types	Manual and automatic
Call Collection Types	Down-collective, full-collective, A.P.B (single-call)

Table 3.0 - Product Description

Models	Control System Types	Number of Stops	Operating Voltages
XC-8GL/2S	Gearless Control System	Up to 8 stops	12V AC (±10%)
XC-8GL/3S	Gearless Control System	Up to 8 stops	12V AC (±10%)
XC-16GL/2S	Gearless Control System	Up to 16 stops	12V AC (±10%)
XC-16GL/3S	Gearless Control System	Up to 16 stops	12V AC (±10%)
XC-8GL2S/SC	Gearless Selective Collective Control System	Up to 8 stops	12V AC (±10%)
XC-8GL3S/SC	Gearless Selective Collective Control System	Up to 8 stops	12V AC (±10%)

Table 4.0 - Model Description

2.2 Basic Settings

Number	Basic Settings	
1	It is recommended to adjust Lock Error ON.	
2	It is recommended to adjust Emergency to ON; in case of an Emergency Device is available.	
3	It is recommended to connect R, S, T and Neutral N to terminal CN5 in case of emergency usage.	
4	<p>Make sure the following symbols appear on the LCD board screen when enabling the safety program.</p> <div style="border: 1px solid black; padding: 5px; margin: 10px auto; width: fit-content;"> <p>F2 S4 ETLC :: NORM LOCK 7</p> </div>	
	Symbol	Function
	E	Emergency = ON
	T	Operation timeout = ON
	L	Lock error = ON
	C	Keycode = ON

Table 5.0 - Basic Settings

3.0 Installation and Connections

3.1 Car and Shaft

The terminals of the Car and Shaft are connected as illustrated in Figure 2.0.

- The Car and Shaft terminals (CN12) are responsible for the selector magnet switches, the floor level magnetic switches, the direction limit switches, the inspection terminal, the overweight terminal, the full weight terminal, the fire unit terminal, the car priority switch, and the safety circuit terminals, which include: the stop, the slip, the fork, and the lock terminals.
- The Car and Shaft terminals (CN12) are different in contact connections, either NO (Normally Open) or NC (Normally Closed), whether the connections are direct to the XC-GL series or indirect through an external relay as illustrated in Figure 2.0.
- The Car and Shaft terminals (CN12) are supplied from CM+ (CN12).

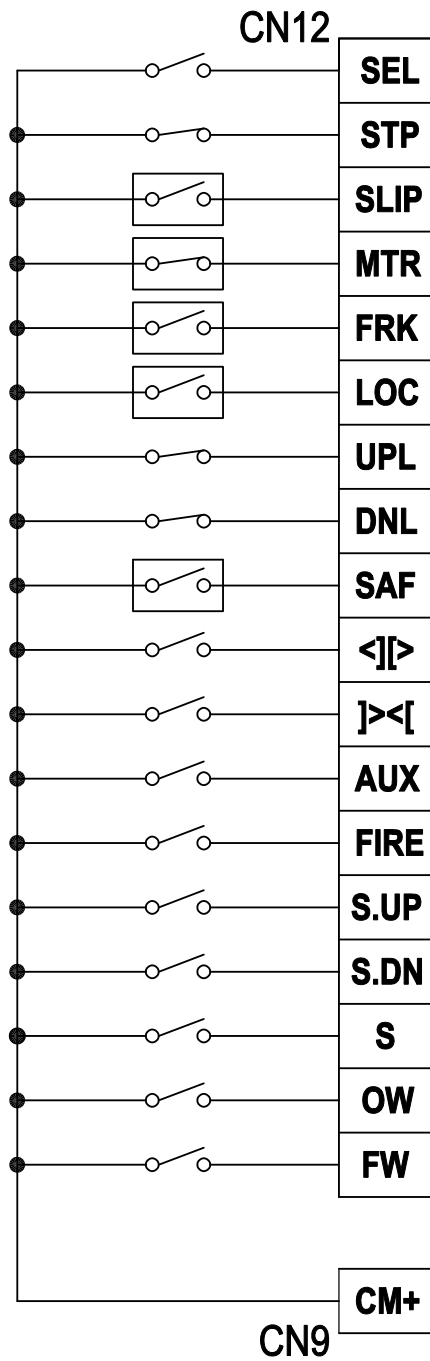
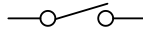
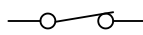
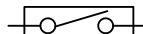



Figure 2.0 - Car and Shaft Connections

Note:

-  Directly connected NO contact
-  Directly connected NC contact
-  Indirectly connected NO contact via relay
-  Indirectly connected NC contact via relay

3.1.1 SEL

The SEL terminal (CN12) is responsible for the counter operation and the speed switching from the fast to the slow speed in the XC-GL series. The SEL terminal (CN12) is directly connected to its assigned magnetic switch, a NO (Normally Open) switch, which switches states according to the detected magnetic elevator strips installed in the shaft, enabling the counter to increment or decrement according to the direction of motion. The incrementation and decrementation process is viewed on the LCD board screen of the XC-GL series.

Note:

Each floor is assigned two magnetic elevator strips for the appropriate magnetic switch, which are recognized and counted by the program. The selector magnetic switch is responsible for switching the car's speed, from fast to slow.

3.1.2 STP

The STP terminal (CN12) is responsible for stopping the car at its desired floor level. The STP terminal (CN12) is directly connected to its assigned magnetic switch, a NC (Normally Closed) switch, which switches states according to the detected magnetic elevator strips installed in the shaft.

Note:

Each floor is assigned one magnetic elevator strip for the appropriate magnetic switch. The magnetic elevator strip installed in the shaft should be placed in a suitable position so that the level of the car is well-aligned with the level of the floor.

3.1.3 SLIP

The SLIP terminal (CN12) is responsible for safely operating the car in its optimum range of operation. The SLIP (CN12) terminal is indirectly connected to the NC (Normally Closed) over travel limit switches at the upward and downward limits of the car's vertical range of operation in the shaft, through an external relay. The connections of the SLIP terminal (CN12) are furtherly illustrated in Figure 14.0.

3.1.4 MTR

The MTR (Motor overcurrent) terminal (CN12) is responsible for detecting the motor overcurrent signal through an external device. The MTR terminal (CN12) is directly connected to the NC (Normally Closed) contact terminals of the respective fast speed overload and slow speed overload.

Note:

In case of a resulting overcurrent in the motor, the car continues its motion and stops on the nearest floor to safely evacuate passengers.

3.1.5 FRK

The FRK terminal (CN12) is responsible for the safe operations of the floor door contacts. The FRK terminal (CN12) is connected to the door contacts of each floor, through an external relay. The connections of the FRK terminal (CN12) are furtherly illustrated in Figure 14.0.

3.1.6 LOC

This LOC terminal (CN12) is responsible for the safe operations of the floor door lock contacts. The LOC terminal (CN12) is connected to the door lock contacts of each floor, through an external relay. The connections of the LOC terminal (CN12) are furtherly illustrated in Figure 14.0.

3.1.7 UPL

The UPL terminal (CN12) is responsible for speed switching on the uppermost floor. The UPL terminal (CN12) is directly connected to it's assigned NC (Normally Closed) up-limit switch in the shaft.

3.1.8 DNL

The DNL terminal (CN12) is responsible for the speed switching on the ground floor. The DNL terminal (CN12) is directly connected to it's assigned NC (Normally Closed) up-limit switch in the shaft.

3.1.9 SAF

The SAF terminal (CN12) is responsible for stopping the car due to an action performed from the over-speed governor, the inspection box stop, the car emergency stop, the pit stop, and the car buffer. The SAF terminal (CN12) is connected to the NC (Normally Closed) contacts of the safety stop circuits mentioned, through an external relay. The connections of the SAF terminal (CN12) are furtherly illustrated in Figure 14.0.

3.1.10 <][>

The '<][>' terminal (CN12) is responsible for the fast opening of the car's automatic door. The '<][>' terminal (CN12) is connected to the NO (Normally Open) contacts of the push buttons of the COP (Car Operating Panel).

Note:

This terminal only operates if the car is on the same level as the floor and the door type installed is automatic.

3.1.11]<>[

The ']<>[' terminal (CN12) is responsible for the fast closing of the car's automatic door. The ']<>[' terminal (CN12) is connected to the NO (Normally Open) contacts of the push buttons of the COP (Car Operating Panel).

Note:

This terminal only operates if the car is on the same level as the floor and the door type installed is automatic.

3.1.12 AUX

The AUX terminal (CN12) is responsible for the VIP (Car Priority) operations, assigning the car to fulfill a single call at a time and cancel all registered calls. The AUX terminal (CN12) is directly connected to the NO (Normally Open) contacts of the push button of the COP (Car Operating Panel).

The methods for operation of the AUX terminal (CN12) are explained in the following section.

- When the AUX terminal (CN12) is activated (AUX = ON) during car execution of the registered calls, the elevator stops at the first registered floor after the first registered call is executed, while the rest of the registered calls are canceled and wait for registration of the desired floor.
- In the case that the AUX terminal (CN12) is activated (AUX = ON) and the car is present on a floor, the car waits for the registration of the car priority call and moves towards its direction immediately.
- In the case that there are no registered calls and an automatic door type, the door remains open until further action is required.
- When the AUX terminal (CN12) is deactivated (AUX = OFF), the car restores its normal mode of operation.

3.1.13 FIRE

The FIRE terminal (CN12) is responsible for determining the default action provided by the XC-GL series according to the action of the external fire alarm unit. In case of fire hazards, the car will immediately move to the assigned fire floor. The FIRE terminal (CN12) is directly connected to the NO (Normally Open) contacts of an external fire alarm unit if present.

The methods for operation of the FIRE terminal (CN12), Program P23: Fire Man (Section 5.10) are explained in the following section.

- When the car moves in the direction of the programmed fire floor, all the registered car calls are canceled and the car will continue to move to its defined floor.
- If the car moves in the opposite direction of the programmed fire floor, all the registered car calls are canceled and the motion speed is switched to slow and the car will move for four seconds and stop shortly after. Afterwards, the car will then move to its defined floor.

3.1.14 SERVICE

The SERVICE terminals (CN12) are responsible for enabling the operator to move the car in the inspection mode using the following three terminals S, UP, and DN. The S terminal (CN12) is connected to the inspection selector switch in the inspection box. The UP terminal (CN12) is connected to the UP NO (Normally Open) push button in the inspection box to move the car in the upward direction. The DN terminal (CN12) is connected to the DOWN NO (Normally Open) push button in the inspection box to move the car in the downward direction.

3.1.15 OW

The OW (Overweight) terminal (CN12) is responsible for ensuring the car remains idle in case of excessive weight in the car. The OW (Overweight) terminal (CN12) is connected to the NO (Normally Open) terminal of the overweight signal in the weight detection device as illustrated in Figure 2.2.

Note:

The OW (Overweight) signal in the car is activated until the required weight of the car is in the appropriate range of operation, once the OW (Overweight) signal is deactivated, the car regains its normal operation conditions.

3.1.16 FW

The FW (Full Weight) terminal (CN12) is responsible for ensuring the car lands on the requested car calls and denies external call requests, until the required weight in the car is in the appropriate range of operation. The FW (Full Weight) terminal (CN12) is connected to the NO (Normally Open) terminal of the full weight signal in the weight detection device as illustrated in Figure 2.2.

Note:

The FW (Full Weight) signal in the car is activated until the required weight of the car is in the appropriate range of operation, once the FW (Full Weight) signal is deactivated, the car is ready to execute external calls again.

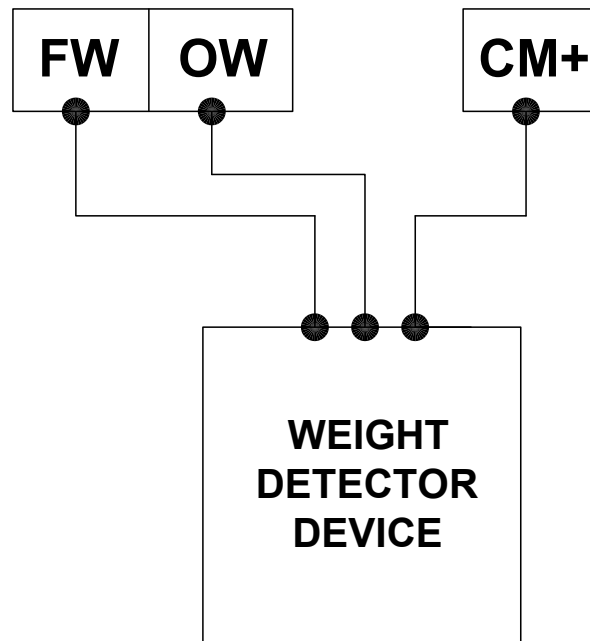

Figure 2.1 - Weight Signal Connections

- If It isn't used, it should be connected to CM⁺.

3.2 Serial Indicator (XD-S)

The terminals of the Serial Indicator are connected as illustrated in Figure 3.0.

Note:

The Serial Indicator (XD-S) can operate simultaneously with the 7-Segment Indicator or the Binary Indicator (XD-B) or the Floor Wire Indicator.

- The positive terminal (+12V) of the Serial Indicator (XD-S) is connected to the positive bridge terminal (+12V).
- The GND terminal of the Serial Indicator (XD-S) is connected to the negative bridge terminal (-12V).
- The DISP terminal of the Serial Indicator (XD-S) is connected to the DISP terminal (CN11) of the XC-GL series.
- It is recommended to connect the negative terminal of the bridge (-12V) to the GND terminal (CN9) of the XC-GL series.

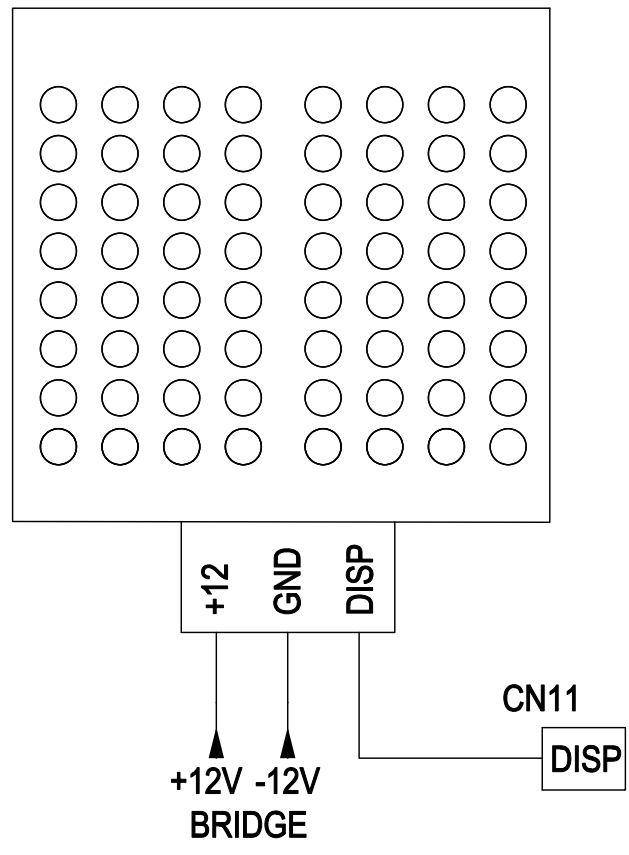

Figure 3.0 - Serial Indicator Connections

3.3 7-Segment Indicator

The terminals of the 7-Segment Indicator are connected as illustrated in Figure 4.0.

- The positive terminal of the 7-Segment Indicator (+12V) is connected to the positive terminal of the external bridge (+12V).
- Terminals A, B, C, D, E, F, G and H of the 7-Segment Indicator are connected to the replicate lettered terminals (CN10) on the XC-GL series.
- It is recommended to connect the negative terminal of the external bridge (-12V) to the GND terminal (CN9) of the XC-GL series.

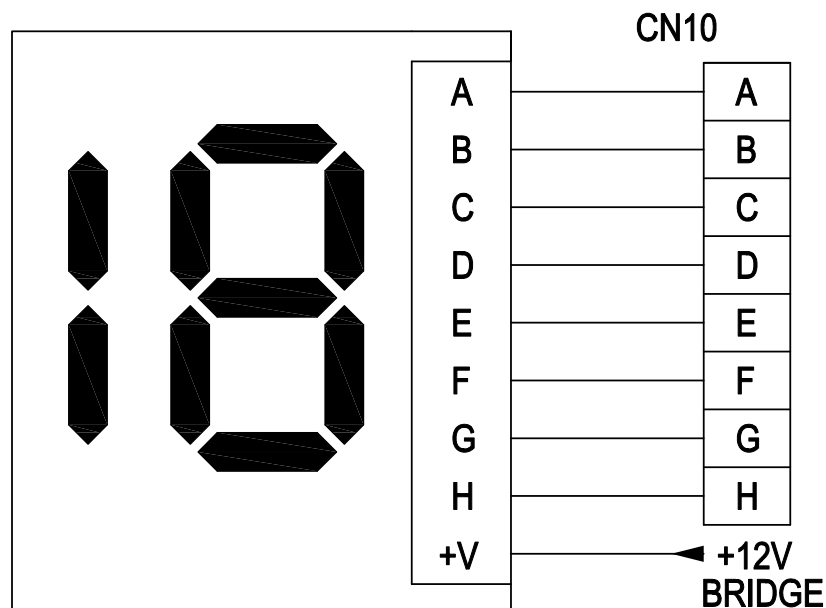

Figure 4.0 - 7-Segment Indicator Connections

3.4 Floor Wire Indicator

The terminals of the Floor Wire Indicator are connected as illustrated in Figure 5.0 for a maximum of eight stops.

- The positive terminal of the Floor Wire Indicator (+12V) is connected to the positive terminal of the external bridge (+12V).
- Terminals A, B, C, D, E, F, G and H of the Floor Wire Indicator are connected to the replicate lettered terminals (CN10) on the XC-GL series.
- In case the number of stops exceed eight stops and are up to twelve stops, the number of displays can be extended to accommodate twelve displays using the extension board (XE-1) through the following steps:
 - Internal call terminals from (0-3) on the extension board are used as car calls for stops from (9-12).
 - External call terminals from (0-3) on the extension board are used as landing calls for stops from (9-12).
 - Internal call terminals from (4-7) on the extension board (XE-1) are used as Floor Wire Indicator terminals for stops from (9-12).
- It is recommended to connect the negative terminal of the bridge (-12V) to the GND terminal (CN9) of the XC-GL series.

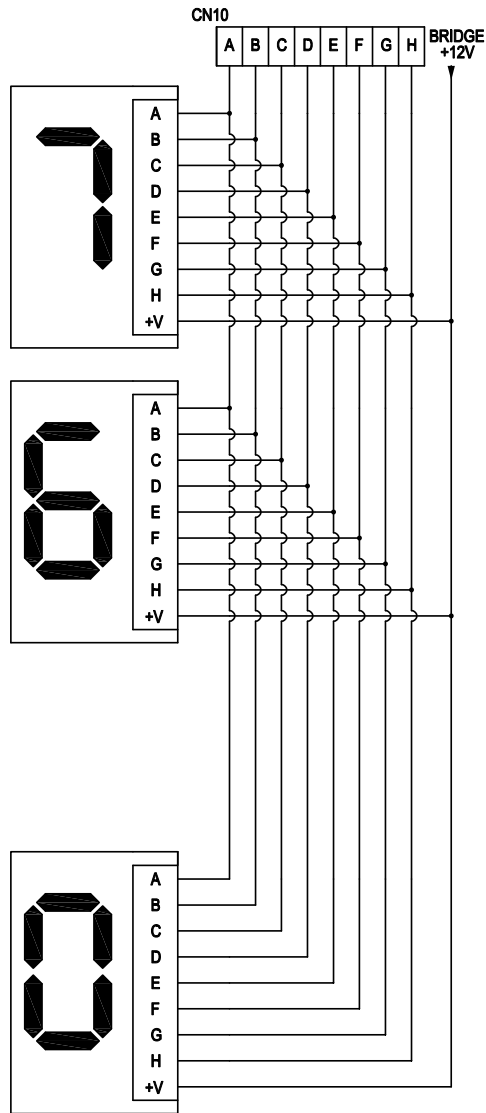

Figure 5.0 - Floor Wire Indicator Connections

3.5 Car and Landing Calls

The Car (internal) and Landing (external) Call terminals are connected as illustrated in Figure 6.0.

- The first terminal of the CPBB (Car Push Button Bulb) is connected to the positive terminal of the external bridge (+12V).
- The second terminal of the CPBB (Car Push Button Bulb) should be connected to the call terminal (CN7 and CN8) on the XC-GL series board with one terminal of the CPBC (Car Push Button Contact).
- The second terminal of the CPBC (Car Push Button Contact) is connected to the COM terminal (CN9) on the XC-GL series board.
- It is recommended to connect the negative terminal of the external bridge (-12V) to the GND terminal (CN9) of the XC-GL series board.
- It is recommended to use a 1A diode between the CPBB (Car Push Button Bulb) and the CPBC (Car Push Button Contact) to avoid dim lighting on push button call, caused by cable noise.

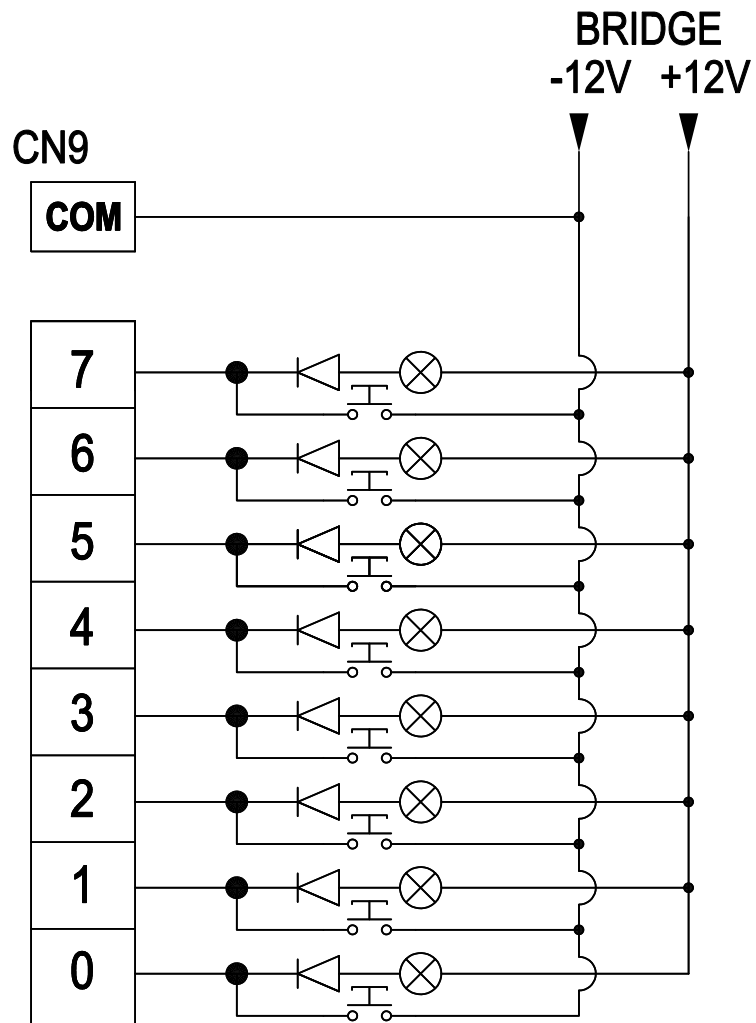

Figure 6.0 - Car and Landing Call Connections

3.6 Arrow Signals

The terminals of the Arrows (Up and Down) are connected as illustrated in Figure 7.0.

- Figure 7.0 illustrates the installation and wiring of the Arrow Signals in case of not applying the hydraulic functionality.
- The ARC terminal (CN13) is connected to the negative terminal of the external bridge (-12V).
- The AU terminal (CN13) is connected to the first terminal of the Up Arrow LED and the second terminal is connected to the positive external bridge terminal (+12V).
- The AD terminal (CN13) is connected to the first terminal of the Down Arrow LED and the second terminal is connected to the positive external bridge terminal (+12V).

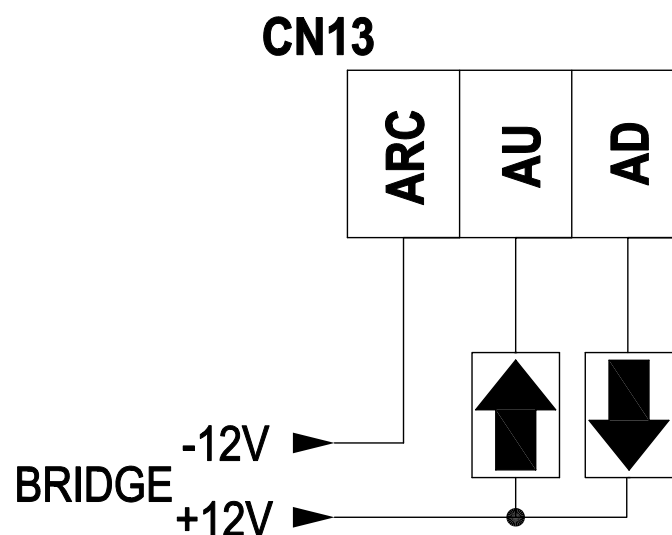

Figure 7.0 - Arrow Signals Connections

3.7 Gong Signals

The terminals of the Gong Signals (Fast and Slow) are connected as illustrated in Figure 8.0.

- The ANC terminal (CN14) is connected to the negative terminal of the bridge (-12V).
- The A.FT terminal (CN14) is connected to the first terminal of the Fast Gong and the second terminal is connected to the positive terminal of the external bridge (+12V).
- The A.SL terminal (CN14) is connected to the first terminal of the Slow Gong and the second terminal is connected to the positive terminal of the external bridge (+12V).

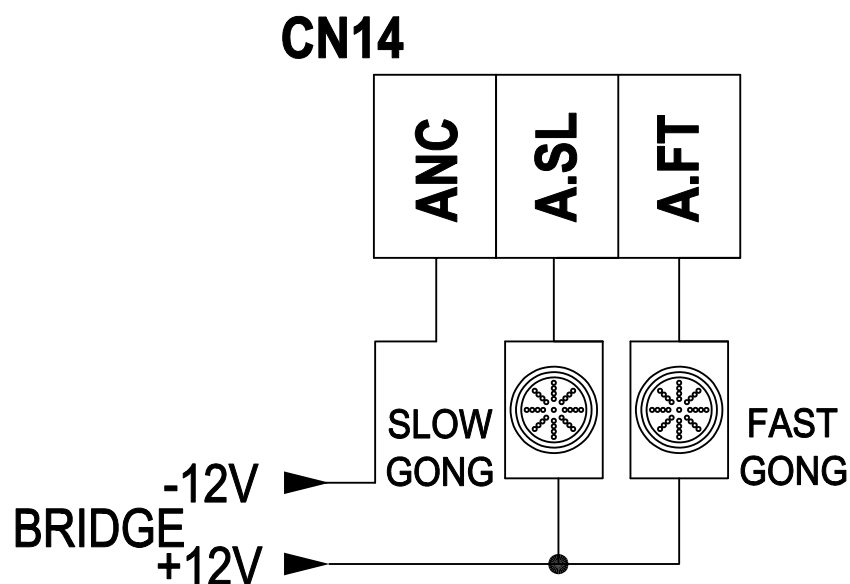

Figure 8.0 - Gong Signal Connections

3.8 Manual Doors

The Manual Door operating terminals are wired and connected as illustrated in Figure 9.0.

- The CAM connector is responsible for operating the doors.
- For Manual Doors operating through a Retiring CAM, the external CAM contactor is connected to the XC-GL series as illustrated in Figure 9.0.
- The Retiring CAM is operated by the DC voltage of the external bridge through the contactor as illustrated in Figure 9.0.

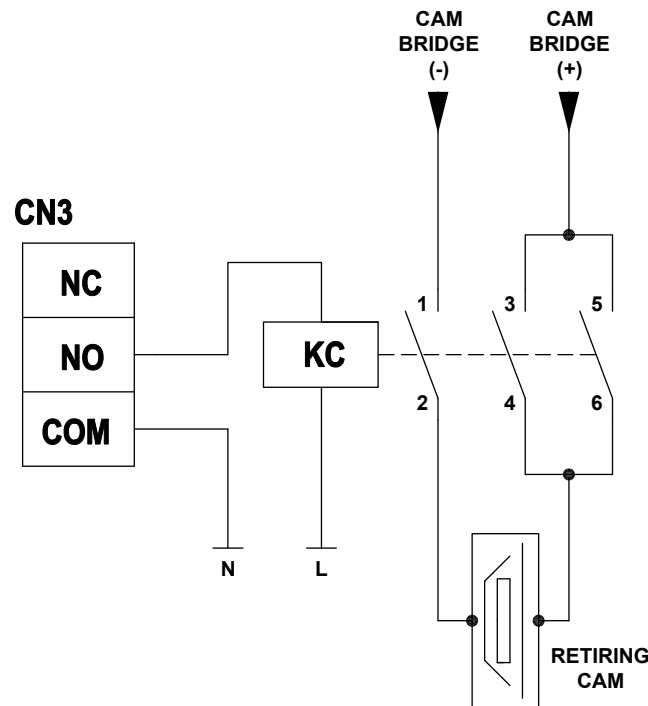

Figure 9.0 - Manual Door Connections

3.9 Three-Phase Automatic Doors

The terminals of operating the Three-Phase Automatic Door are wired and connected as illustrated in Figure 10.0.

- Operating the Three-Phase Automatic Door requires two contactors for opening and closing.
- The Normally Open (NO) terminal (CN3) is responsible for closing the Three-Phase Automatic Door.
- The Normally Closed (NC) terminal (CN3) is responsible for opening the Three-Phase Automatic Door.
- The terminals of the closing and opening limit switches must be combined into the Three-Phase Automatic Door operation circuit as illustrated in Figure 10.0.

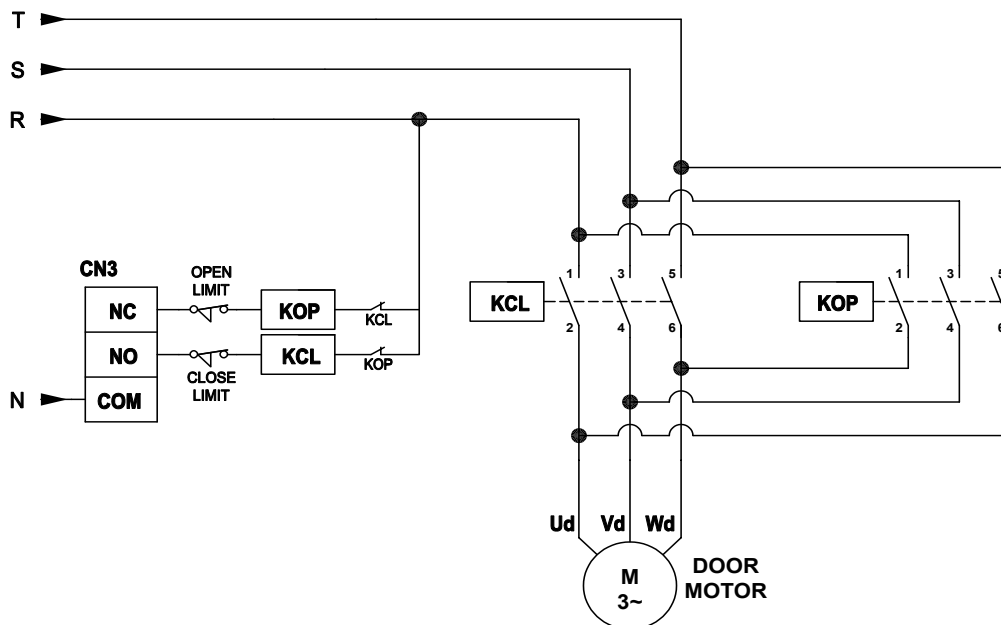

Figure 10.0 - Three-Phase Automatic Door Connections

3.10 Single-Phase Automatic Doors

The terminals of operating the Three-Phase Automatic Door are wired and connected as illustrated in Figure 11.0.

- The Single-Phase Automatic Door signals are connected to the terminals of the CAM connector (CN3) in the XC-GL series as the following:
- The Normally Open (NO) terminal (CN3) is connected to the Single-Phase Automatic Door closing signal.
- The Normally Closed (NC) terminal (CN3) is connected to the Single-Phase Automatic Door opening signal.
- The COM signal of the Single-Phase Automatic Door is connected to the CAM relay COM (CN3) of the XC-GL series.

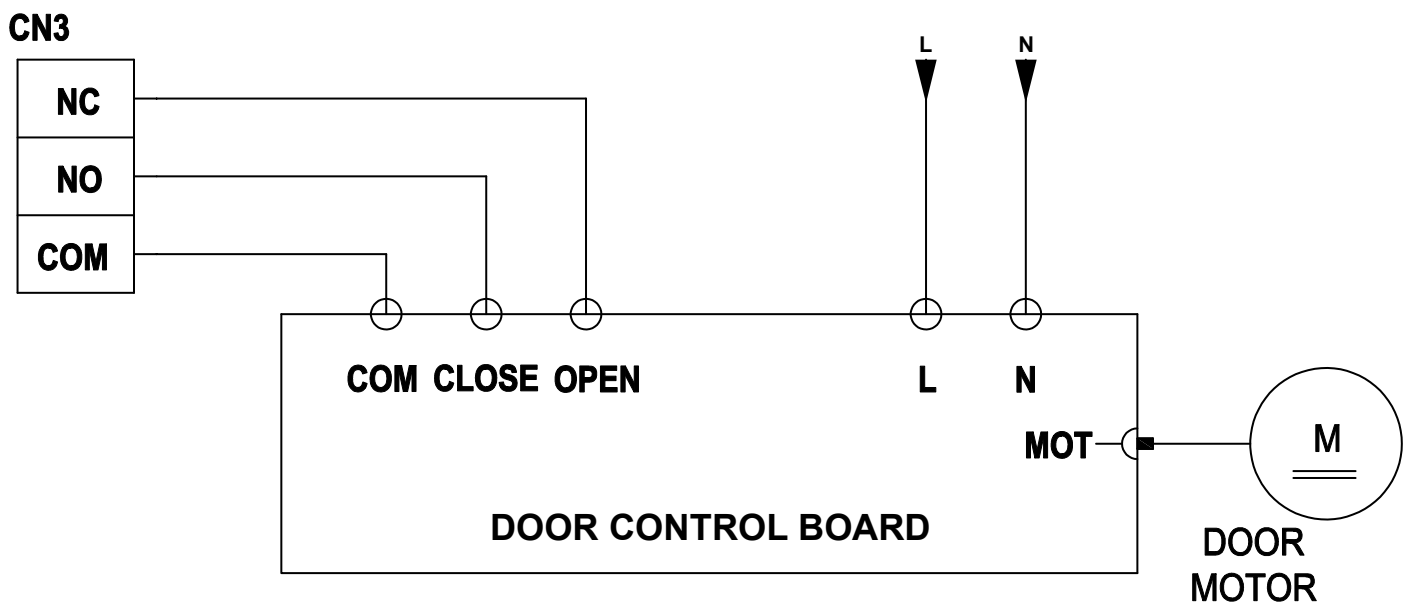

Figure 11.0 - Single-Phase Automatic Door Connections

3.11 Single-Phase Semi-Automatic Doors

The terminals of operating the Single-Phase Semi-Automatic Door are wired and connected as illustrated in Figure 11.0.

- In this case, the door is considered as a Manual Door, therefore the CAM terminal (CN3) is connected as illustrated in Figure 12.0.
- A 12V DC relay should be in use. Moreover, the CAM contactor must have NC (Normally Closed) and NO (Normally Open) contacts.

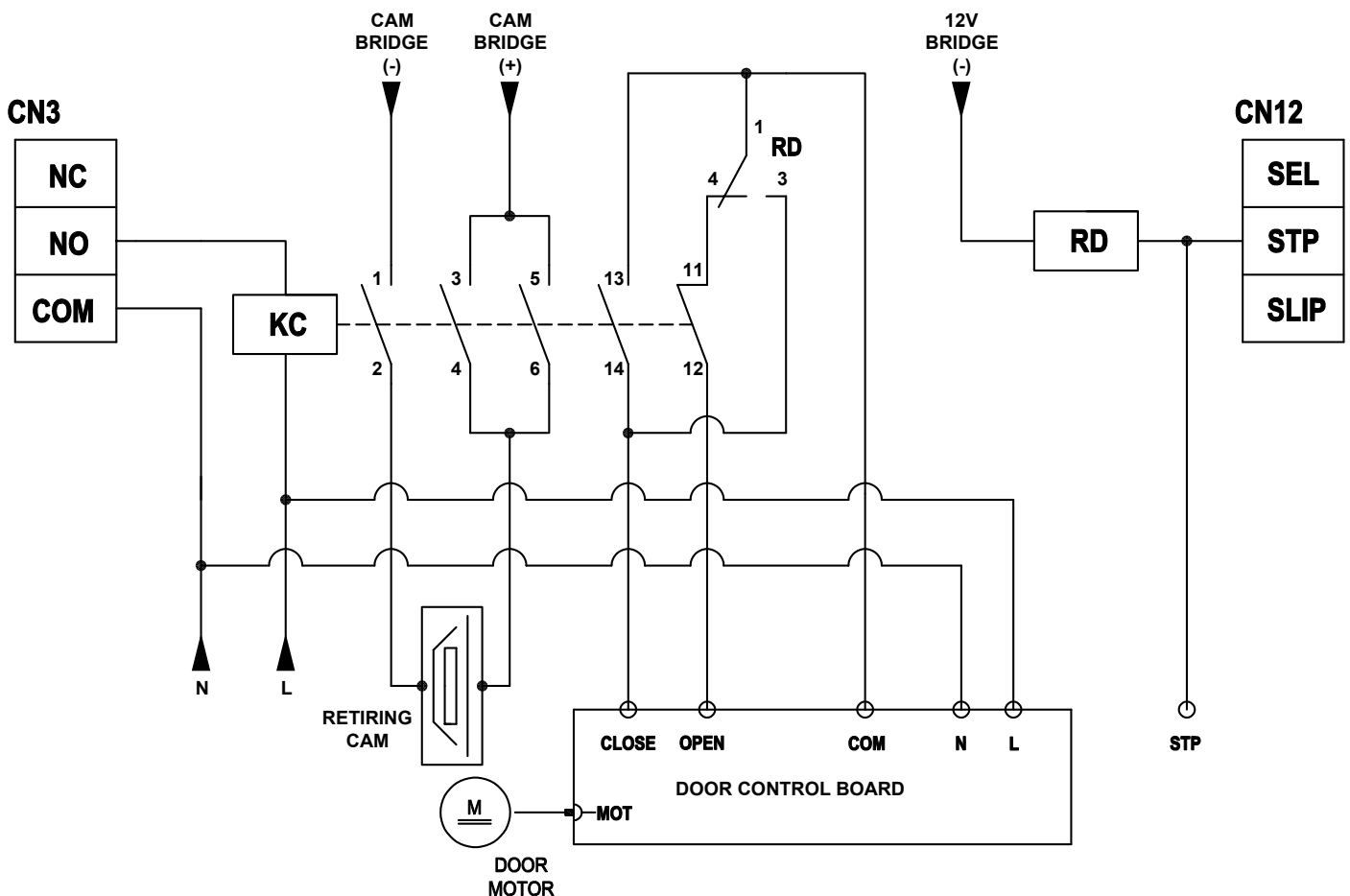

Figure 12.0 - Single-Phase Semi-Automatic Door Connections

3.12 Inverter Motion Signals and Power Supply

The terminals of the Inverter Motion Signals and Power Supply are connected as illustrated in Figure 13.0.

- The operation of the inverter is controlled either through the selection of the three-phase power supply or the emergency UPS device, based on the actions taken by the board according to phase failure status and indications illustrated in Figure 13.0.
- The Motion signal terminal (CN4) of the XC-GL series board is connected to the appropriate terminal of the inverter.
- The EMR terminal (CN4) of the XC-GL series board is connected to the appropriate emergency input of the inverter.
- Figure 13.0 illustrates the connection of the XC-GL series board with the inverter, the UPS device, the machine motor, and the braking system.

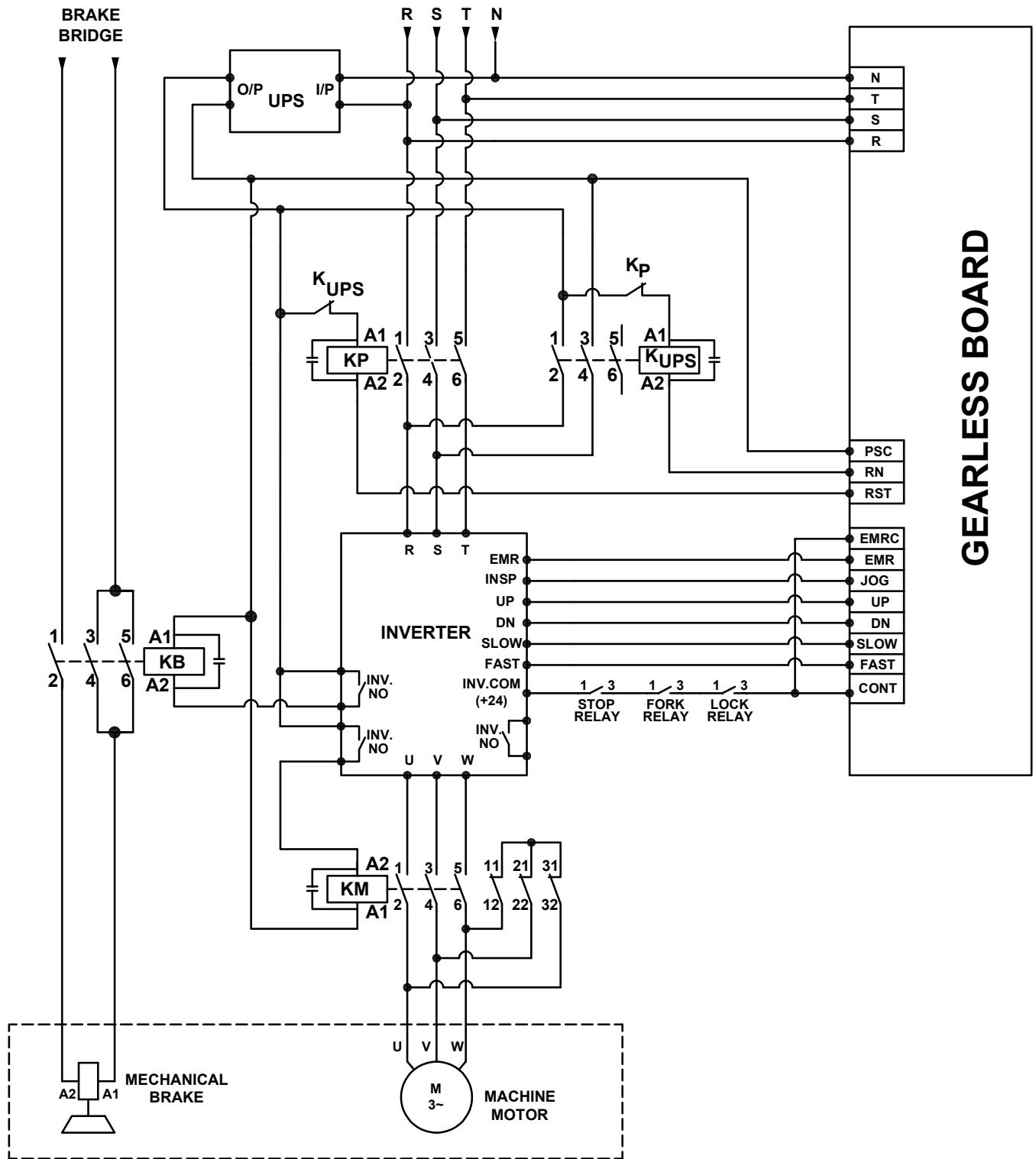

Figure 13.0 - Inverter Motion Signals and Power Supply Connections

3.13 Safety Circuits

The terminals of the Safety Circuits are connected as illustrated in Figure 14.0.

- Figure 14.0 represents a guide for connecting Safety Circuits to the shaft terminals (CN12) on the XC-GL series board.
- The Safety Circuits are operated with 60V DC using an external relay as illustrated in Figure 14.0.
- A series connection is recommended in the following order: +60V DC, Stop Circuit, Slip Circuit, Door contacts, and Door Locks contacts respectively. This will disable elevator operation in case of malfunction or failure in any of the mentioned circuits.
- Figure 14.0 represents the condition when all safety circuits are closed, where the car can operate normally.

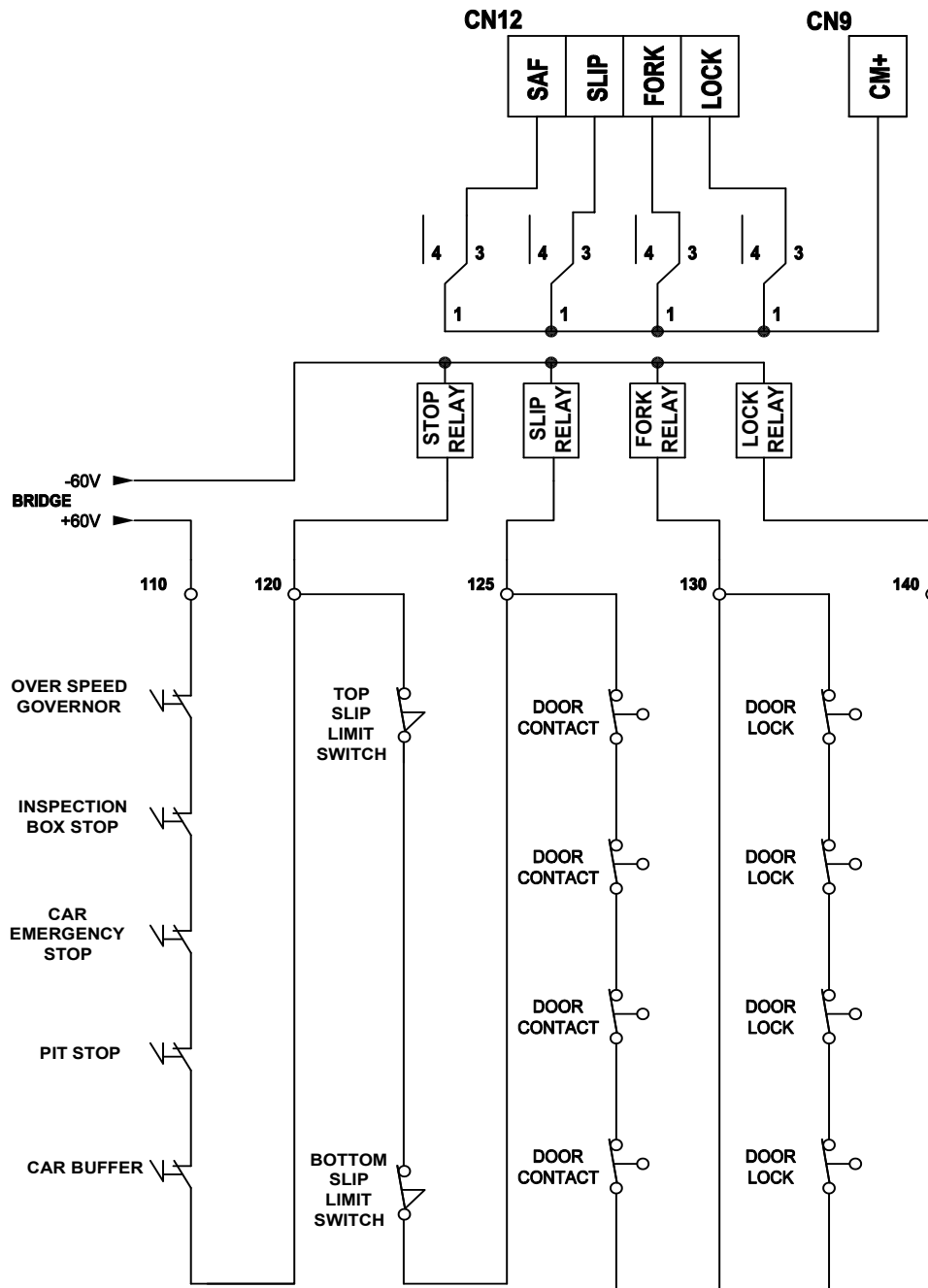

Figure 14.0 - Safety Circuit Connections

3.14 Magnetic Configuration

Figure 15.0 illustrates the configuration of the magnetic slide positions with the floor levels, according to the position of the selector and the level magnet.

- Speed switching from FAST to SLOW is done through the selector magnet switch and it's magnetic slides for all of the floors except the ground and the last stop.
- Speed switching in the ground and the last stop are done through the Up and Down limit switches.

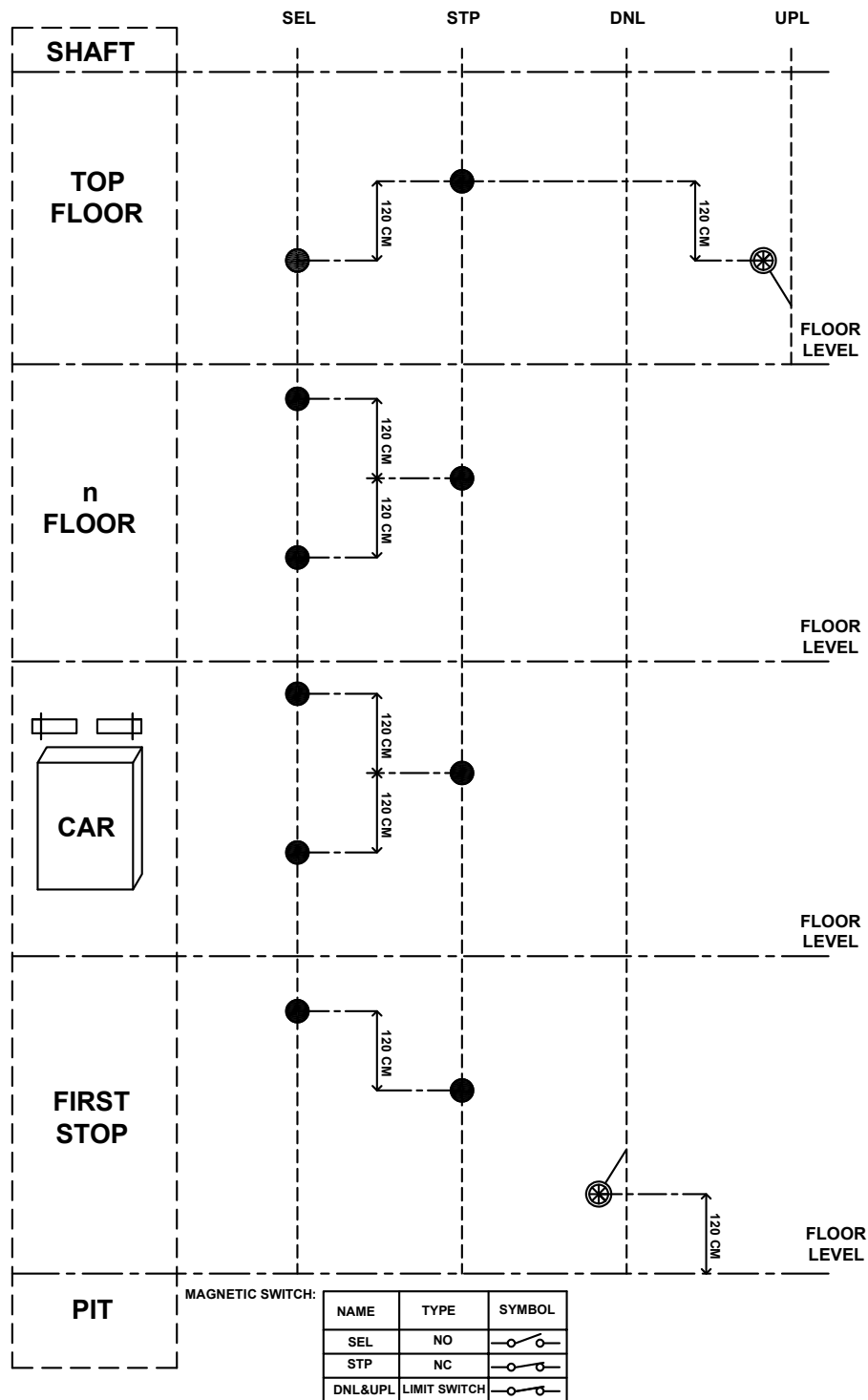

Figure 15.0 - Magnetic Configuration

3.15 Car

The terminals of the Car are connected as illustrated in Figure 16.0.

- Figure 16.0 illustrates the connection of the traveling cable terminals between the main control panel and the car for calls, indicators, inspection box, etc.

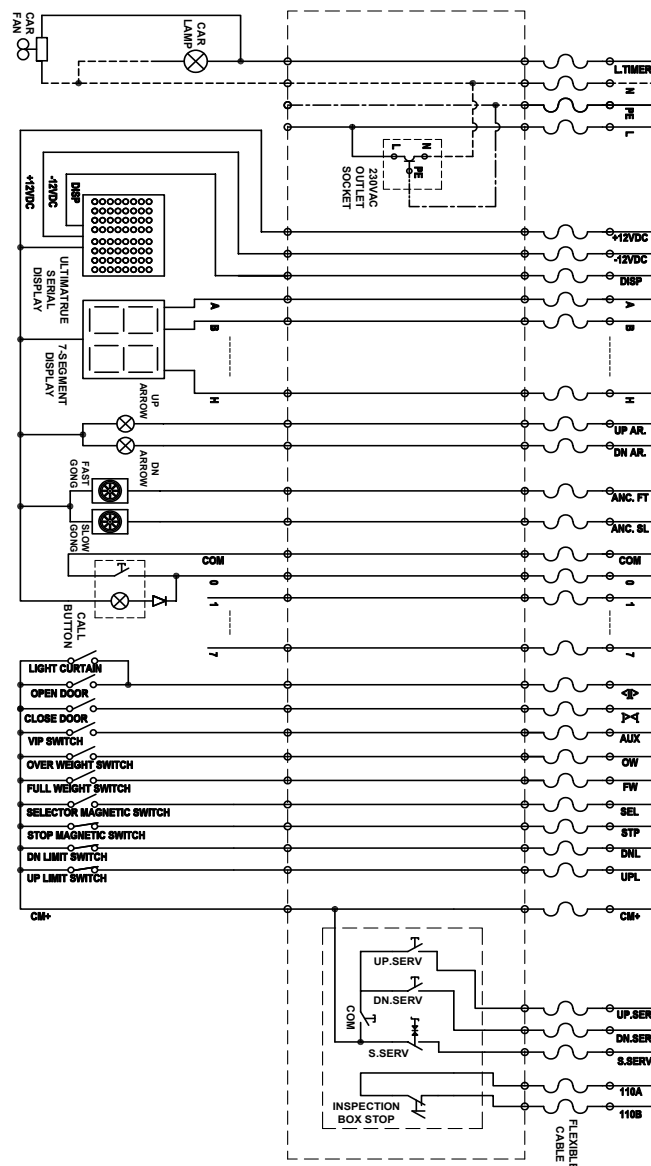

Figure 16.0 - Car Connections

4.0 Basic Programming

Programming Mode Guide

The programming mode is operated using four push buttons on the XC-GL series board.

- Reset: For entering and exiting the programming mode.
- Enter: For entering the programming mode or the programming steps, modification, and saving.
- (-) and (+) : Moving between programming steps.

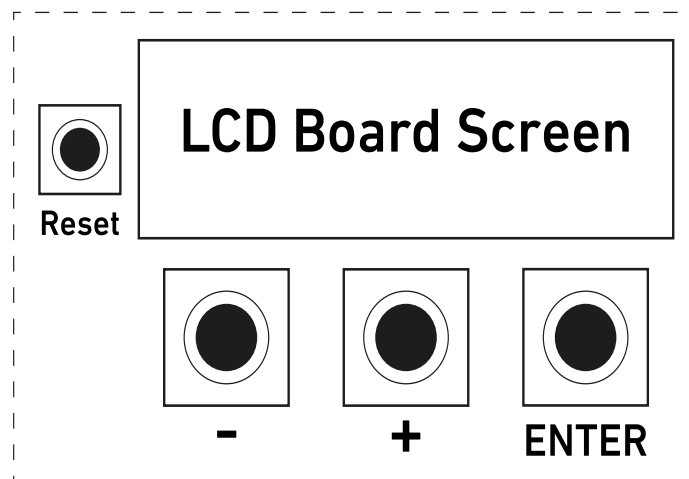

Figure 17.0 - Programming Guide Layout

Basic Programs Login

Press the RESET button for two seconds, and then press and hold ENTER during the appearance of the welcome message. The second line contains production and version information.

ULTIMATRUE XC-8G
GL Y22M3-V7.30

When the next screen appears, release the ENTER button then Press (+) button to go to the password screen:

Press (+) key

Enter the password using (+) or (-) buttons. To go to the next digit, press ENTER.

Enter Password
00000

Note:

The factory setting password is (00000).

After entering the correct password and pressing ENTER, the user will be directed to the basic program mode.

4.1 Program P1: Floor Number

This program is used to determine the number of active stops (doors).

- The number of active doors can be determined up to 16 stops (doors).
- Press ENTER to access this program or (+ or -) to select another program.
- After accessing this program, press (+ or -) to determine the number of stops, and then press ENTER after selection for saving. Stop numbers start from zero, thus for programming 8 stops select 7, and for programming 16 stops select 15.

P1 > Floor Number
Floor No: 7

4.2 Program P2: Display Mode

This program is used to determine the type of Indicator used from points A-to-H.

Press ENTER to access this program or (+ or -) to select another program.

After accessing the program, press (+ or -) to select the suitable display mode. In case of selecting 7-segment or binary indicator mode, the stop coordination screen will appear, enabling the user to select the required number to be displayed when the car is at the floor.

Display:
7SEGMENT

Display:
Floor Wire

Display:
Binary NEG

Display:
Binary POS

Note:

The left side digit (tens) can be assigned value of 'none' or '1', while the right side digit (units) can be assigned values ranging from these characters '0', '1', '2', '3', '4', '5', '6', '7', '8', '9', 'F', 'G', 'P', '-' or 'space'.

The program sequence is as follows:

- Press (+) or (-) to change the left digit.

Floor 0 : 0

- Press ENTER to go to the right digit.
- Press (+) or (-) to change the right digit.
- When finished, press ENTER and a 'Store' message will appear temporarily.
- Press ENTER again to save the number and go to the next stop (floor) or (+ or -) if you want to readjust the same stop (floor).
- Repeat the previous steps, until all stops (floors) are assigned the required display pattern.

4.3 Program P3: LED Matrix (XD-S)

This program is used to assign the required two-character alphanumeric combination for each stop that will be used with the RS232 serial indicator.

Note:

Only Ultimatrue Engineering Industries' elevator control Serial Indicators (XD-S) can be used.

- Press ENTER to access this program or (+ or -) to select another program.
- When using the serial indicator, complete ASCII printable characters are available for assignment to each of the two digits thus offering a very big symbol/character combination for any stop.
- After accessing the program, press (+ or -) to adjust each digit location as follows:

Floor 0 : 0

- Press (+) or (-) to change the left digit.
- Press ENTER to go to the right digit.
- Press (+) or (-) to change the right digit.
- When finished, press ENTER and a 'Store' message will appear temporarily.

- Press ENTER again to save the number and to go to the next stop or (+ or -) if you want to readjust the same stop.
- Repeat the previous steps, until all stops are assigned the required display pattern.

4.4 Program P4: Door Type

This program is used to select the suitable door type.

- Press ENTER to access this program or (+ or -) to select another program

Door: Manual

Door: Wait - Close

Door: Wait - Open

- After accessing this program, press (+ or -) to select the suitable door type.
- When finished, press ENTER to save and to go to the next program.

4.5 Program P5: System Type

This program is used to select the suitable system type.

- Press ENTER to access this program or (+ or -) to select another program.
- After accessing this program press (+ or -) to select the used system type.

System: Two-Speed

System: Three-Speed

- When finished, press ENTER to save and to go to the next program.

4.6 Program P6: Collective

This program is used to select the method of serving landing calls.

- Press ENTER to access this program or (+ or -) to select another program.
- After accessing this program, press (+ or -) to select the required collective type.
 - DOWN COLL.: Serving calls in the DOWN direction only.

Collective: Down coll.

- SEMI COLL.: Serving calls in the UP and DOWN directions.

Collective: Semi coll.

- APB: Serving one call at a time.

Collective: APB coll.

- When finished, press ENTER to save and to go to the next program.

4.7 Program P7: Wait Time

This program adjusts the time that the car will wait when arriving at a stop before moving again to serve the next call.

- Press ENTER to access this program or (+ or -) to select another program.
- After accessing this program, press (+ or -) to set the required time from 2-to-30 seconds.

Wait Time: 4

- When finished, press ENTER to save and to go to the next program.

4.8 Program P8: CAM Time

This program adjusts the waiting time from the beginning of the CAM relay on the board working till lock closure.

- Press ENTER to access this program or (+ or -) to select another program.
- After accessing this program, press (+ or -) to set the required time from 2-to-10 seconds for manual doors.

CAM Time: 3

Note:

For automatic doors, the user can select different periods of time for opening and closing the door.

CAM Open: 3

CAM Close: 3

- When finished, press ENTER to save and to go to the next program.

4.9 Program P9: Slow Time

This program adjusts the maximum time for moving the car with the SLOW speed, after which the car will automatically halt.

- Press ENTER to access this program or (+ or -) to select another program.
- After accessing this program, press (+ or -) to set the required time from 4-to-25 seconds.

Slow Time: 8

- When finished, press ENTER to save and to go to the next program.

4.10 Program P10: Fast Time

This program adjusts the maximum time for moving the car with the FAST speed, after which the car will automatically halt.

Note:

In case of the unavailability of a selector and floor-level pulses, the Fast Time program will trigger an event to stop the motor and XC-GL series operations until the issue is resolved. In case of the availability of floor level pulses only, the car will continue moving in the same direction until it reaches the upper or lower limit switch, then moves at the SLOW speed, then stops at the floor level. This scenario ensures the safe evacuation of passengers in all Fast Time events.

- Press ENTER to access this program or (+ or -) to select another program.
- After accessing this program, press (+ or -) to set the required time from 10-to-90 seconds.

Fast Time: 15

- By pressing ENTER you will go to the supervisor step selection to specify how to get back to the normal mode of operation in case of a Fast Time Error.
- Press (+ or -) to select the mode ON or OFF.

- The supervisor mode ON will keep the XC-GL series out of function displaying Fast Time Error even if the control board is reset, while supervisor mode is OFF normal operations of the XC-GL series board are present when reset.
- To quit the supervisor mode ON and return to normal mode of operation, the XC-GL series must enter the Inspection Mode and exit it.
- This action ensures that a qualified person supervises the cause of the Fast Time Error before the elevator is back to normal operations again.
- When finished, press ENTER to save and to go to the next program.

4.11 Program P11: Lamp Time

This program adjusts the time for the car light.

- Press ENTER to access this program or (+ or -) to select another program.
- After accessing this program press (+ or -) to set the required time from 1-to-90 seconds.

Lamp Time: 8

- When finished, press ENTER to save and to go to the next program.

4.12 Program P12: Emergency

This program adjusts the preference of using built-in emergency actions that will control the inverter in case of power failure.

- Press ENTER to access this program or (+ or -) to select another program.
- After accessing this program, press (+ or -) to select the mode ON or OFF.

Emergency:
0 OFF

Emergency:
1 ON

- After Selecting the ON mode, press ENTER to set the time which the board waits after the power is OFF and start to turn on the RN relay. Press (+) or (-) to set this time from 4-to-50 seconds.

Rn: 5

- When finished, press ENTER to set the time between operating the RN relay and the start of the emergency signal. Press (+) or (-) to set the time from 1-to-20 seconds.

EMR Time: 2

- When finished, press ENTER to set the time between operating the emergency signal and starting to operate the UP direction signal, press (+) or (-) to set this time from 0-to-20 seconds.

EMR: 2

- When finished, press ENTER to save and to go to the next program.

4.13 Program P13: Keycode

This program adjusts the preference of using the built-in COP (Car Operating Panel) as a three-digit access code entry keypad. The selected code sequence should be selected within the range of operating car calls terminals on the XC-GL series.

- Press ENTER to access this program or (+ or -) to select another program.
- After accessing this program, press (+ or -) to select the mode ON or OFF.

KeyCode
0 OFF

KeyCode
1 ON

- When selecting the ON mode, you will be directed to a screen to adjust the required access sequence.

SET KEY CODE
<<123>>

- Press (+ or -) to change the first digit, and then press ENTER to move and adjust the second and third digits.
- When finished, press ENTER to save and to go to the next program.

5.0 Advanced Programming

Advanced Programs Login

Press the RESET button for two seconds, then press and hold ENTER during the appearance of the welcome message. The second line contains production and version information.

ULTIMATRUE XC-8G
GL Y22M3-V7.3

When the next screen appears, release the ENTER button then Press and hold (-) button then press the (+) button to go to the password screen:

PRESS (+) KEY

Enter the password using (+) or (-) buttons. To go to the next digit, press ENTER.

Note:

The factory setting password is (00000).

ENTER
PASSWORD
00000

- After entering the correct password and pressing ENTER, the user will be directed to the advanced program mode.

5.1 Program P14: CAM Trials

This program adjusts the number of CAM trials after which the control board will suspend operation. Selecting '0' means that the control board will drop all calls after the default CAM action and the control board can accept re-registering calls and repeating the CAM action indefinitely.

Note:

In case the CAM fails to close the lock with the number of defined programmed trials, all calls are canceled to protect the CAM from overheating or damage.

- Press ENTER to access this program or (+ or -) to select another program
- After accessing this program, press (+ or -) to set the required CAM trials from 0-to-10 times.

CAM Trials: 0

- When finished, press ENTER to save and to go to the next program.

5.2 Program P15: Fork Time

This program adjusts the time duration where the elevator remains idle and there are registered calls and the door contact is open. After this time, all calls are canceled.

Note:

Fork Time for manual doors, the time range is from 1-to-4 minutes, after the time has elapsed, the controller will cancel all calls, in case of failure of the manual door's close-contact (Floor). Fork Time for automatic doors, the door contact (fork) is used as an auxiliary lock point for the internal automatic door. It is recommended to connect it to the CM+ terminal if it's not intended to be used.

- Press ENTER to access this program or (+ or -) to select another program.
- After accessing this program, press (+ or -) to set the required time from 1-to-4 minutes.

Fork Time: 4

- When finished, press ENTER to save and to go to the next program.

5.3 Program P16: Park Time

This program adjusts the period of time during which the elevator remains idle with no registered calls (Park Time). After this period, the elevator will automatically move to a preset parking stop (Park Floor). To cancel this feature, adjust the park time to a value greater than 29 minutes, the screen will display a '0 OFF' message.

- Press ENTER to access this program or (+ or -) to select another program.
- After accessing this program press (+ or -) to set the required time from 1-to-29 minutes.

Park Time: 4
1 ON

- Press ENTER to save and go to the next screen, through which the parking stop (floor) is determined.

Park Floor: 0

- When finished, press ENTER to save and to go to the next program.

5.4 Program P17: Operation Timeout

This program adjusts the period of time after which the XC-GL series will stop working. This function is useful for forced routine maintenance checks. The period can be adjusted from 1-to-6 months.

- Press ENTER to access this program or (+ or -) to select another program.
- After accessing this program, press (+ or -) to set the required parameter.
- OFF: The XC-GL series will operate indefinitely.

```
Oper.Timeout:
  0  OFF
```

- ON: The XC-GL series will operate for the defined period.

```
Oper.Timeout:
  1  ON
```

- The ON selection will initiate the period screen to adjust the operation period from 1-to-6 months.

```
Period:
  1  Month
```

- RESTART: The operation time will be reset and disabled.

Oper.Timeout: 2 Restart

- When finished, press ENTER to save and to go to the next program.

5.5 Program P18: Service Telephone

This program adjusts the service company telephone number so that it can be displayed on the LCD board screen in case of operation period timeout which stops the elevator from working.

- Press ENTER to access this program or (+ or -) to select another program.
- After accessing this program, press (+ or -) to set the required telephone digit by digit.

Service Tel. 000000000000

- When finished, press ENTER to save and to go to the next program.

5.6 Program P19: Set Password

This program enables you to change the password to log on into the two programming modes.

- Press ENTER to access this program or (+ or -) to select another program.
- After accessing this program, press (+ or -) to set the first digit of the basic password.

Basic Password
>>00000<<

- Press ENTER to move to the next digit and adjust it.
- Repeat the same sequence for the five digits.
- Press ENTER to save and go to advanced password settings.

Advanced Password
>>00000<<

- Enter the required password in the same manner of the basic password.
- When finished, press ENTER to save and to go to the next program

5.7 Program P20: Active Floor

This program can enable or disable every landing or car call button independently. This function is useful for intentionally making certain floor(s) out of service. 'EXTERNAL' stands for landing calls while 'INTERNAL' stands for car calls.

Note:

The Active Floor program facilitates maximum programming control, in which excluding a stop (internally, externally, or both) is set using the Active Floor programming mode, without the necessity of removing the elevator stops' wiring from the XC-GL series.

- Press ENTER to access this program or (+ or -) to select another program.
- After accessing this program, press (+ or -) to set the required parameter as preferred.
- OFF: The indicated stop (floor) number call button will be disabled internally or externally.

Floor 0: External 0 OFF

- ON: The indicated stop (floor) number call button will be enabled internally or externally.

Floor 0: External
1 ON

- After choosing, press ENTER then press (+ and -) together to confirm selection.

Floor 0: External
Press code

- When finished, press ENTER to save and to go to the next program.

5.8 Program P21: Lock Error

This program can enable or disable the lock error function. This program is useful for continuously monitoring the lock contact during each call served at any stop. This feature is supposed to ensure the safety of the door lock when activated. In this sense, it is necessary to open the lock contact every time the car stops on the floor. In case of not opening the lock contact, the car will not move to ensure passenger's safety.

- Press ENTER to access this program or (+ or -) to select another program.
- After accessing this program, press (+ or -) to set the required parameter as preferred.

Lock Error:
0 OFF

Lock Error:
1 ON

- After choosing, press ENTER then press (+ and -) together to confirm selection.

Lock Error:
Press Code

- When finished, press ENTER to save and to go to the next program.

5.9 Program P22: Max Calls

This program can select the maximum number of car calls that can be registered at a time. This feature is supposed to secure the elevator from any abnormal passenger behavior, where the registration of car calls greater than the preset Maximum Calls will not be accepted.

- Press ENTER to access this program or (+ or -) to select another program.
- After accessing this program, press (+ or -) to set the required parameter as preferred.

Max Calls:
0 OFF

Max Calls:
4 Calls

- After choosing, press ENTER then press (+ and -) together to confirm selection.

Max Calls:
Press Code

- When finished, press ENTER to save and to go to the next program.

5.10 Program P23: Fire Man

This program can enable/disable the fireman actions taken in case of fire alarm signals. The Fire Floor is the default stop that the elevator automatically will go to in case of fire.

- Press ENTER to access this program or (+ or -) to select another program.
- After accessing this program, press (+ or -) to set the required parameter as preferred.

Fire Man:
0 OFF

Fire Man:
1 ON

- After choosing the ON mode, press ENTER then press (+ and -) together to confirm selection.
- Then the screen determining the Fire Floor will be displayed.

Fire Man:
Press Code

Fire Floor: 0

- Press (+ or -) to determine or set the required floor as preferred.
- When finished, press ENTER to save and to go to the next program.

5.11 Program P24: Factory Set

This program is used to restore all the XC-GL series settings to its factory defaults.

- Press ENTER to access this program or (+ or -) to select another program.

Factory Set:
Press Code

- After accessing this program, press (+ and -) together to confirm selection.

Factory Set: OK

- When finished, press ENTER to save and to go to the next program.

5.12 Program P25: Restore Selector

This program is supposed to correct the selector counter by going to the ground floor every time the power is OFF and back ON again.

- Press ENTER to access this program or (+ or -) to select another program.
- After accessing this program, press (+ or -) to select the mode ON or OFF.

Restore Selector: 0 OFF

Restore Selector: 1 ON

- When finished, press ENTER to save and to go to the next program.

5.13 Program P26: Service Control (Inspection Mode)

This program enables the operator to control the elevator in inspection mode using programming buttons, so that (+) button is used to move the car in the UP direction, the (-) button is used to move the car in the DOWN direction, and the ENTER button is used to exit this mode.

Note:

There exists an interlock between activation of the Service Control (Inspection Mode) program and the inspection signal from the shaft to prioritize maximum safety for the technician.

- For program activation, press the ENTER and the (+) buttons together during normal mode. In the case of XC-GL series boards, this mode is activated without the need of accessing the programming steps.
- For moving the car, (+) or (-) buttons are used according to the desired direction.
- When finished, press ENTER to save and to go to the next program.

6.0 Additional Programming

6.1 Binary Indicator (XD-B)

Programming Values	Displayed Symbols on Binary Indicator (XD-B)
0	BLANK
1	P1
2	G
3	M
4	1
5	2
6	3
7	4
8	5
9	6
10	7
11	8
12	9
13	10
14	11
15	12
16	13
17	14
18	15
19	16

Table 6.0 - Binary Indicator (XD-B) Programming

7.0 Malfunction Diagnosis

7.1 LCD Board Screen

As an advantage of the XC-GL series, faults and errors can be viewed on the LCD board screen in both error codes and notations.

Error Code	Error Notation	Description
1	SLIP	Over Travel Error
2	MTR	Motor Over Current Error
3	UPLM	UP Limit Error
4	DNLM	DOWN Limit Error
5	S-F, S-L	Safe Fork and Safe Lock
6	FORK	Manual Door Contact Error
7	LOCK	Door Lock Contact Error
8	SERV	Inspection Mode
9	STOP	Car Stop
10	FIRE	Fire Alarm
11	RESERVED	---
12	FSTT	Fast Time Error
13	O.WT	Overweight
14	EMER	Emergency Mode
	*	Short Circuit On The Call Push Button

Table 7.0 - LCD Board Screen Error View

7.2 7-Segment Indicator

Error Notation	Description
E	Open UP or Down Limit
L	Safe Lock
C	Car Stop
H	Phase Fail Error
F	Fast Time Error
U	Fork Time Error
n	MTR (Motor Overload)
≡	Slip, Inspection Mode, and Overweight

Table 8.0 - 7-Segment Indicator Error View

7.3 Serial Indicator (XD-S)

Error Notation	Description
US	Slip
MT	Motor Overload
UL	Open UP Limit
DL	Open DOWN Limit
LK	Safe Lock Error
ST	Car Stop
FR	Fire
SV	Inspection Mode
CE	Serial Indicator Communication Error
DR + Floor Number	Open Door Contact and Fork Time Error
PH	Phase Fail Error
FT	Fast Time Error
OW	Overweight

Table 9.0 - Serial Indicator Error View

8.0 Disclaimer

The manufacturer shall have no obligation for damage, injury, or any legal responsibility incurred directly or indirectly from the use of any of the products. The user shall observe safe and lawful practices including, but not limited to, those set forth in this document. Should further information be desired or should particular obstacles arise which are not specifically covered for the client's purposes, the matter should be referred to Ultimatrue Engineering Industries.

Ultimatrue Engineering Industries reserves the right to make technical changes or modify the contents of this document without prior notification. With regard to purchase orders, the agreed particulars shall prevail. Ultimatrue Engineering Industries does not accept any responsibility for possible lack of information in this document.

Ultimatrue Engineering Industries reserves all rights in this document and in the subject matter and illustrations contained therein. Any reproduction, disclosure to third parties, or utilization of its content - in whole or in part - is forbidden without prior consent of Ultimatrue Engineering Industries.

© Copyright 2023 Ultimatrue Engineering Industries.

All rights reserved.

9.0 Warranty

Ultimatrue Engineering Industries warrants the XC-GL series board against all manufacturing defects for a period of one year after the date of installation and operation, provided that the user strictly adheres to all technical specifications and instructions illustrated in the user manual. The warranty is not valid in the following cases:

- Defects caused by failures or mistakes in the XC-GL series board connections or wiring.
- Defects caused by incorrect introduction of high or low voltage.
- Defects caused by misuse and non-compliance with the illustrated operating instructions in the user manual.
- Defects caused by intended damages or fire.

Index:

7-Segment Indicator, 5-6, 23, 25
46, 82.

A

Active Floor, 71.
Advanced Programming, 5,
62-63.
Automatic, 5-6, 10, 18-19, 33-34,
54, 65.

B

Basic Programming, 43-44.
Binary Indicator, 23, 46, 80.

C

CAM, 6, 32, 34-35, 54, 64.
Control System, 11.

D

Diagnosis, 5, 81.

E

Error, 5, 12, 56-57, 73, 81-83.

F

Floor Wire Indicator, 23,
26-27, 46.
Fork, 5, 13, 65, 81-83.

I

Inverter, 6 10, 36-37, 59.
Inspection, 6, 8, 13, 18, 20, 42,
57, 79, 81-83.

M

Magnet, 13, 15, 40-41.
Manual, 5, 8, 10, 32, 35, 50, 54,
63, 81.
Motor, 5, 10, 16, 40-41, 43, 65,
68, 73, 87, 90.

P

Phase, 5-6, 10, 16, 36, 56, 81-83.

S

Semi-Automatic, 35.
Serial Indicator, 5-6, 23-24, 48,
83.
Shaft, 6, 10, 13-17, 38, 79.

X

XC-GL, 5, 8-9, 11, 13, 15, 20, 23,
25-26, 28, 32, 34, 36, 38, 43,
56-57, 61, 67, 71, 77, 79, 81, 85.
XD-B, 5, 23, 81.
XDP-2W, 5.
XD-S, 5, 23, 48, 83.
XD-2W, 5.
XE-1, 5-6, 11, 26.

Ultimatrue Engineering Industries

14 Obour Buildings, Salah Salem St.

11811 Cairo

Egypt

+20 102 366 6065

info@ultimatrue.com

www.ultimatrue.com

As standards, specifications, and design vary over periods of time, please ask for confirmation of the information provided in this publication.

© 2023 Copyright Ultimatrue Engineering Industries. All rights reserved.

XC-GL Series - Version 2.0.
