

# XC-DUP Series

Elevator Control Boards

## User Manual

Version 2.0

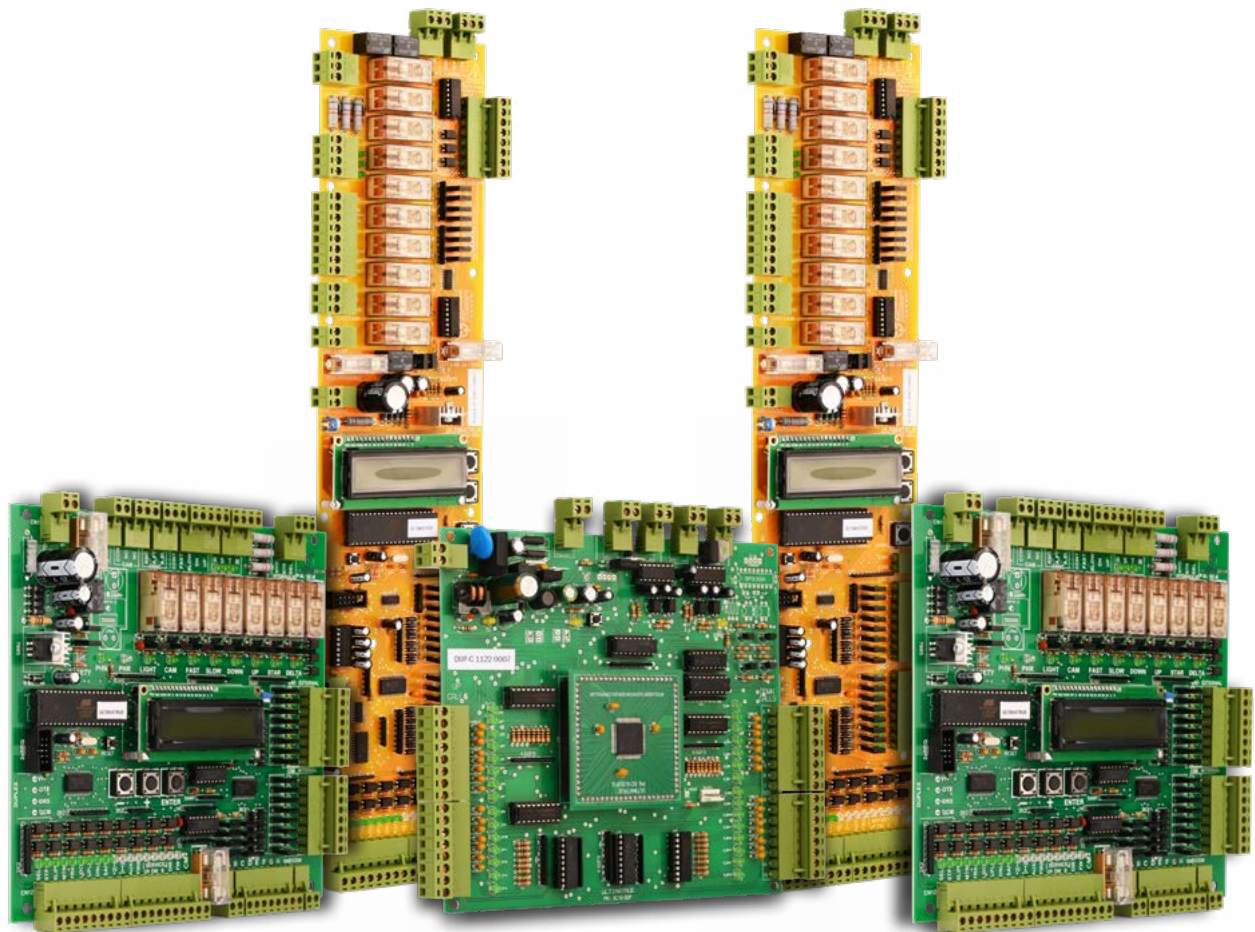

---

**Table of Contents**

1.0	General Description .....	07
1.1	Table of Locations .....	08
1.1.1	XC-DUP Series .....	08
1.2	Safety Precautions .....	14
1.2.1	Transport and Inspection.....	14
1.2.2	Storage .....	14
1.2.3	Warnings and Hazards .....	15
2.0	Technical Specifications .....	16
2.1	Product Description .....	16
2.2	Basic Settings .....	19
2.2.1	XC-DUP-8 Sub-Series:.....	19
2.2.2	XC-DUP-GL Sub-Series .....	20
3.0	Installation and Connections.....	21
3.1	Power Supply .....	21
3.2	Duplex Communication .....	23
3.3	Landing Calls .....	25
3.4	Car and Shaft .....	27
3.4.1	SEL .....	29
3.4.2	STP .....	29
3.4.3	SLIP .....	30
3.4.4	MTR .....	30
3.4.5	FRK.....	31
3.4.6	LOC.....	31
3.4.7	UPL.....	31

3.4.8	DNL.....	31
3.4.9	SAF.....	32
3.4.10	<][>.....	32
3.4.11	]<>[.....	32
3.4.12	AUX.....	33
3.4.13	FIRE.....	34
3.4.14	SERVICE.....	34
3.4.15	OW.....	35
3.4.16	FW.....	35
3.5	7-Segment Indicator.....	37
3.6	Floor Wire Indicator.....	38
3.7	Car Calls.....	40
3.8	Arrow Signals.....	42
3.9	Gong Signals.....	44
3.10	Manual Doors.....	45
3.11	Three-Phase Automatic Doors.....	46
3.12	Single-Phase Automatic Doors.....	47
3.13	Single-Phase Semi-Automatic Doors.....	48
3.14	Inverter Motion Signals and Power Supply.....	50
3.15	Two-Speed Systems.....	52
3.16	Motion Contactors.....	54
3.17	Inverter System.....	56
3.18	Hydraulic System.....	57
3.19	Safety Circuits.....	62
3.20	Magnetic Configuration.....	64
3.21	Car.....	66
4.0	Basic Programming.....	67
4.1	Program P1: Floor Number.....	69
4.2	Program P2: Display Mode.....	70
4.3	Program P3: LED Matrix (XD-S).....	72
4.4	Program P4: Door Type.....	74
4.5	Program P5: System Type.....	75

4.6	Program P6: Collective .....	78
4.7	Program P7: Wait Time .....	79
4.8	Program P8: CAM Time .....	80
4.9	Program P9: Slow Time .....	81
4.10	Program P10: Fast Time .....	82
4.11	Program P11: Lamp Time .....	84
4.12	Program P12: Three Phase Detection.....	85
	4.12.1 Program P12: Phase Sequence.....	85
	4.12.2 Program P12: Emergency .....	86
4.13	Program P13: Keycode.....	88
5.0	Advanced Programming .....	89
5.1	Program P14: CAM Trials .....	91
5.2	Program P15: Fork Time .....	92
5.3	Program P16: Park Time .....	93
5.4	Program P17: Operation Timeout .....	94
5.5	Program P18: Service Telephone .....	96
5.6	Program P19: Set Password.....	97
5.7	Program P20: Active Floor .....	98
5.8	Program P21: Lock Error .....	100
5.9	Program P22: Max Calls .....	101
5.10	Program P23: Fire Man .....	102
5.11	Program P24: Factory Set.....	104
5.12	Program P25: Restore Selector .....	105
5.13	Program P26: Service Control (Inspection Mode).....	106
	5.13.1 Program P26 : Service Control (XC-DUP-8).....	106
	5.13.2 Program P26 : Service Control (XC-DUP-GL) .....	107
6.0	Additional Programming .....	108
6.1	Binary Indicator (XD-B).....	108

7.0 Malfunction Diagnosis..... 109

    7.1 LCD Board Screen ..... 109

    7.2 7-Segment Indicator..... 110

8.0 Disclaimer..... 111

9.0 Warranty ..... 112

Index..... 113

**List of Tables and Figures**

Table 1.0 - XC-DUP Table of Locations ..... 08

Table 2.0 - XC-DUP-8 Table of Locations ..... 10

Table 3.0 - XC-DUP-GL Table of Locations..... 12

Table 4.0 - Warnings and Hazards ..... 15

Table 5.0 - Product Description ..... 17

Table 6.0 - Model Description..... 18

Table 7.0 - Basic Settings (1)..... 19

Table 8.0 - Basic Settings (2)..... 20

Table 9.0 - Motor Speed and Direction Signals..... 57

Table 10.0 - Hydraulic System Connections..... 57

Table 11.0 - Binary Indicator (XD-B) Programming ..... 108

Table 12.0 - LCD Board Screen Error View..... 109

Table 13.0 - 7-Segment Indicator Error View ..... 110

Figure 1.0 - XC-DUP Board Layout ..... 09

Figure 2.0 - XC-DUP-8 Board Layout ..... 11

Figure 3.0 - XC-DUP-GL Board Layout..... 13

Figure 4.0 – XC-DUP Power Supply Connections ..... 22

Figure 5.0 - XC-DUP and Control Boards Connections..... 24

Figure 6.0 - Landing Calls Connections ..... 26

Figure 7.0 - Car and Shaft Connections ..... 28

Figure 8.0 - MTR Connections ..... 30

Figure 9.0 - Weight Signal Connections ..... 36

Figure 10.0 - 7-Segment Indicator Connections ..... 37

Figure 11.0 - Floor Wire Indicator Connections..... 39

Figure 12.0 - Car Call Connections..... 41

Figure 13.0 -XC-DUP-8 Arrow Signals Connections ..... 42

Figure 14.0 -XC-DUP-GL Arrow Signals Connections ..... 43

Figure 15.0 - Gong Signal Connections ..... 44

Figure 16.0 - Manual Door Connections..... 45

Figure 17.0 - Three-Phase Automatic Door Connections..... 46

Figure 18.0 - Single-Phase Automatic Door Connections ..... 47

Figure 19.0 - Single-Phase Semi-Automatic Door Connections ..... 49

Figure 20.0 - Inverter Motion Signals and Power Supply Connections . 51

Figure 21.0 - Two-Speed System Connections..... 53

Figure 22.0 - Three-Phase and Brake Connections..... 55

Figure 23.0 - Inverter System Connections..... 56

Figure 24.0 - Hydraulic System Wiring ..... 60

Figure 25.0 - Gong Signal Connections in the Hydraulic System..... 61

Figure 26.0 - Safety Circuit Connections ..... 63

Figure 27.0 - Magnetic Configuration ..... 65

Figure 28.0 - Car Connections ..... 66

Figure 29.0 - Programming Guide Layout ..... 67

## 1.0 General Description

The XC-DUP series is a duplex elevator control system series that is fully designed and manufactured at Ultimatrue Engineering Industries. The XC-DUP series user manual is segmented into two sub-series, the XC-DUP-8 sub-series and the XC-DUP-GL sub-series. The XC-DUP-8 sub-series operate to serve multiple elevator control board models, which include: XC-DUP-8 and XC-DUP-16. The XC-DUP-8GL sub-series operate to serve multiple elevator control board models, which include: XC-DUP-8GL/2S, XC-DUP-8GL/3S, XC-DUP-16GL/2S, and XC-DUP-16GL/3S. The XC-DUP series operate up to eight stops, with additional features to satisfy customer specifications. The XC-DUP series supports extensions up to sixteen stops using the XE-1 extension board, in addition to all types of brand indicators (XDP-2W& XD-2W, XD-B). The XC-DUP series operate using all motor types (one-speed, two-speed, hydraulic, and gearless), all door types (manual, semi-automatic, wait-open automatic, and wait-close automatic), and elevator call collection types, such as: down-collective and selective-collective. The XC-DUP series contain safety circuits by hardware and by software designed to control speed and direction systems to halt operations if any failures occur in the fork, lock, slip, stop, etc. In addition to an internal three-phase correction system (XC-DUP-8). The XC-DUP series provides a total of twenty-six software programs, distributed across basic and advanced programming functionalities, accustomed with a user-friendly menu interface. The XC-DUP series also provides built-in fault and error diagnosis information that could be viewed on the LCD board screen and the 7-segment indicator.

The XC-DUP series complies with the international lift safety standards EN 81-20 and EN 81-50.

Ultimatrue Engineering Industries is a certified ISO 9001:2015 and ISO 45001:2018 company.



**1.1 Table of Locations**

The XC-DUP consists of three control boards: The DUP control board as a medium for power supply, data communication, and landing calls, alongside two elevator control boards relative to either the XC-DUP-8 sub-series or the XC-DUP-GL sub-series.

**1.1.1 XC-DUP Series**

Pointer	Function
1	Controller power supply
2	Landing calls supply and common
3	First communication circuit supply
4	First communication data circuit
5	Second communication circuit supply
6	Second communication data circuit
7	Upward collective landing calls
8	Downward collective landing calls

**Table 1.0 - XC-DUP Table of Locations**



Pointer	Function
1	Controller power supply
2	Car light signals
3	Automatic door and retiring CAM signal
4	Gong signals
5	Motion signals
6	Three phase and neutral
7	Hydraulic - Arrow signals - Semi-automatic door
8	Landing calls
9	Car calls
10	Calls common - GND
11	Indicator outputs: 7-segment, binary, floor-wire
12	Serial indicator
13	Weight signals
14	Inspection signals
15	Shaft connection signals
16	Duplex socket
17	XE-1 connection socket

Table 2.0 - XC-DUP-8 Table of Locations

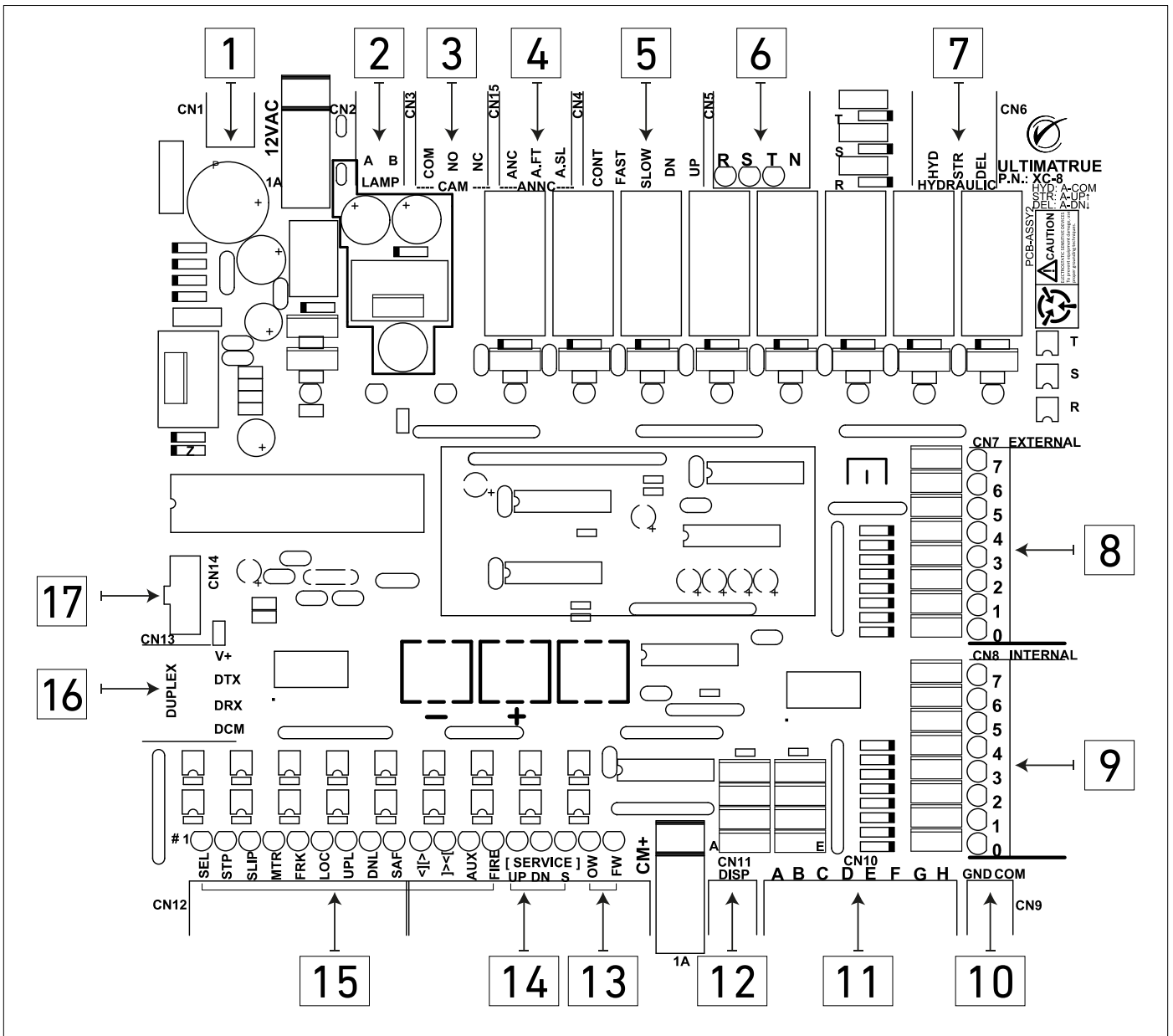

Figure 2.0 - XC-DUP-8 Board Layout

Note:

Please head over to the Installation and Connections section for more information on the individual inputs/outputs.

Pointer	Function
1	Controller power supply
2	Car light signals
3	Automatic door and retiring CAM signal
4	Motor speeds - Direction signals
5	Emergency signal
6	Three-phase and neutral
7	Inverter power supply
8	Car calls
9	Landing calls
10	Shaft common (CM+) and Calls common (COM)
11	Indicator outputs: 7-segment, binary, floor-wire
12	Serial indicator
13	Shaft connection signals
14	Inspection signals
15	Weight signals
16	Duplex socket
17	Arrow signals
18	Gong signals
19	XE-1 connection socket

Table 3.0 - XC-DUP-GL Table of Locations



## 1.2 Safety Precautions

To fully benefit from using the XC-DUP series please read the user manual carefully before installation and initiating operation. Keep it nearby for future reference whenever necessary.

### 1.2.1 Transport and Inspection

The units are delivered from the factory ready for installation.

Upon receiving the XC-DUP series' units please check that the delivered equipment has not been damaged during transport. If any such damage occurs, a claim must be submitted to the carrier immediately.

After unpacking, the following must be checked:

- The XC-DUP series is not damaged.
- The XC-DUP series package is sealed.

### 1.2.2 Storage

The XC-DUP series board must be stored under cover in a dry and well-ventilated area until it's installed and ready for operation.

### 1.2.3 Warnings and Hazards

Before initiating operations, make sure that all connections, wirings, and board connectors are connected properly.

<b>Warnings and Hazards</b>
Never install the XC-DUP series in places subject to rain, direct sunlight, or places with a degree of high dust.
The main power terminals must be kept away from the indicator and call terminals.
Electricity must be turned OFF during the removal or the installation of the XC-DUP series board.

**Table 4.0 - Warnings and Hazards**



## 2.0 Technical Specifications

### 2.1 Product Description

Technical Specifications	Description	
Board Dimensions	XC-DUP-8	19.5 cm * 21 cm + 21 cm * 18.5 cm
	XC-DUP-GL	21 cm * 18.5 cm + 10 cm * 40 cm
Maximum Current Consumption	1 A	
Protection Fuses	Two Fuses (2 A) for supply input and shaft supply as protection	
Operating Temperature	10° C - 45° C	
Storage Temperature	10° C - 60° C	
Motor Types	XC-DUP-8	One-speed, two-speed, and hydraulic
	XC-DUP-GL	Gearless
Drive Types	XC-DUP-8	Contactors and inverters
	XC-DUP-GL	Inverters
Car Speed	XC-DUP-8	Up to 1 m/s
	XC-DUP-GL	Two-speed models: Up to 1 m/s
		Three-speed models: Up to 1.6 m/s
Door Types	XC-DUP-8	Manual, semi-automatic, and automatic
	XC-DUP-GL	Manual and automatic

Technical Specifications	Description
Call Collection Types	Down-collective, Selective Collective

**Table 5.0 - Product Description**

Models	Control System Types	Number of Stops	Operating Voltages
XC-DUP-8	Elevator Group Control System	Up to 8 stops	12V AC (±10%)
XC-DUP-16	Elevator Group Control System	Up to 8 stops expandable to 16 stops using the extension board (XE-1)	12V AC (±10%)
XC-DUP-8GL/2S	Gearless Elevator Group Control System	Up to 8 stops (up to 1 m/sec)	12V AC (±10%)
XC-DUP-8GL/3S	Gearless Elevator Group Control System	Up to 8 stops (up to 1.6 m/sec)	12V AC (±10%)
XC-DUP-16GL/2S	Gearless Elevator Group Control System	Up to 8 stops expandable to 16 stops using the extension board (XE-1) ( up to 1m/sec)	12V AC (±10%)
XC-DUP-16GL/2S	Gearless Elevator Group Control System	Up to 8 stops expandable to 16 stops using the extension board (XE-1) (Up to 1.6 m/sec)	12V AC (±10%)

Table 6.0 - Model Description

2.2 Basic Settings

2.2.1 XC-DUP-8 Sub-Series:

Number	Basic Settings	
1	It is recommended to adjust Lock Error ON.	
2	It is recommended to enable PH.SEQ/FAIL.	
3	It is recommended to operate the MTR terminal (CN12) to achieve maximum safety during operation.	
4	<p>Make sure the following symbols appear on the LCD board screen when enabling the safety program.</p> <div style="border: 1px solid black; padding: 5px; margin: 10px auto; width: fit-content;"> <p><b>F2 S4 PTLC</b> <b>NORM LOCK 7</b></p> </div>	
	Symbol	Function
	P	Phase correct = ON
	T	Operation timeout = ON
	L	Lock error = ON
	C	Keycode = ON

Table 7.0 - Basic Settings (1)

2.2.2 XC-DUP-GL Sub-Series

Number	Basic Settings	
1	It is recommended to adjust Lock Error ON.	
2	It is recommended to adjust Emergency to ON; in case of an Emergency Device is available.	
3	It is recommended to connect R, S, T and Neutral N to terminal CN5 in case of emergency usage.	
4	<p>Make sure the following symbols appear on the LCD board screen when enabling the safety program.</p> <div style="border: 1px solid black; padding: 5px; margin: 10px auto; width: fit-content;"> <p><b>F2 S4 ETLC ::</b> <b>NORM LOCK 7</b></p> </div>	
	Symbol	Function
	E	Emergency = ON
	T	Operation timeout = ON
	L	Lock error = ON
	C	Keycode = ON

Table 8.0 - Basic Settings (2)

### 3.0 Installation and Connections

Please refer to the XC-DUP series and XC-GL series user manuals for installation and connection instructions for the respective XC-DUP-8 series and XC-DUP-GL series.

#### 3.1 Power Supply

The terminals of the Power Supply are connected as illustrated in Figure 4.0.

- Figure 4.0 illustrates the connection of the XC-DUP series Power Supply with the 12V AC from the first and second control panels through an external relay, to ensure continued operations of the XC-DUP series in case of electrical power failure in one of the control panels.
- The used relay is preferably an 11-pin 60V DC relay, provided that the connections are as follows:
- The two terminals of the XC-DUP series' Power Supply are connected to the common contacts of the relay (contacts 1 and 6 in Figure 4.0).
- The 12V AC terminal supplied from the first control panel's transformer of which the XC-DUP series is installed is connected to the NO (Normally Open) contacts of the relay (contacts 3 and 7 in Figure 4.0).
- The 12V AC terminal supplied from the second control panel's transformer is connected to the NC (Normally Closed) contacts of the relay (contacts 4 and 5 in Figure 4.0).

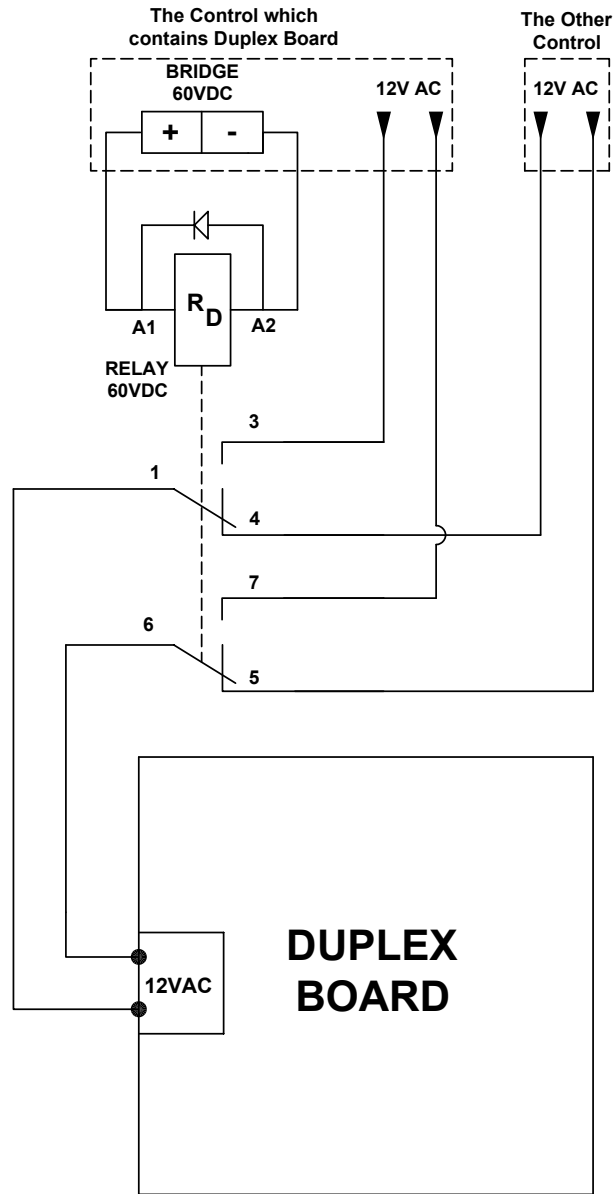

Figure 4.0 – XC-DUP Power Supply Connections

### 3.2 Duplex Communication

The terminals for the Duplex Communication are connected as illustrated in Figure 5.0.

- Figure 5.0 illustrates the connection of the XC-DUP series with the associated control boards from the duplex connection socket.
- The P1 terminal (CN3) of the XC-DUP series is connected to the V+ terminal of the duplex connection socket on the first control board.
- The N1 terminal (CN3) of the XC-DUP series is connected to the DCM terminal of the duplex connection socket on the first control board.
- The T1 terminal (CN4) of the XC-DUP series is connected to the DRX terminal of the duplex connection socket on the first control board.
- The R1 terminal (CN4) of the XC-DUP series is connected to the DTX terminal of the duplex connection socket on the first control board.
- Similarly, terminals P2 and N2 (CN5) and terminals T2 and R2 (CN6) of the XC-DUP series are connected respectively to the duplex connection socket on the second control board.



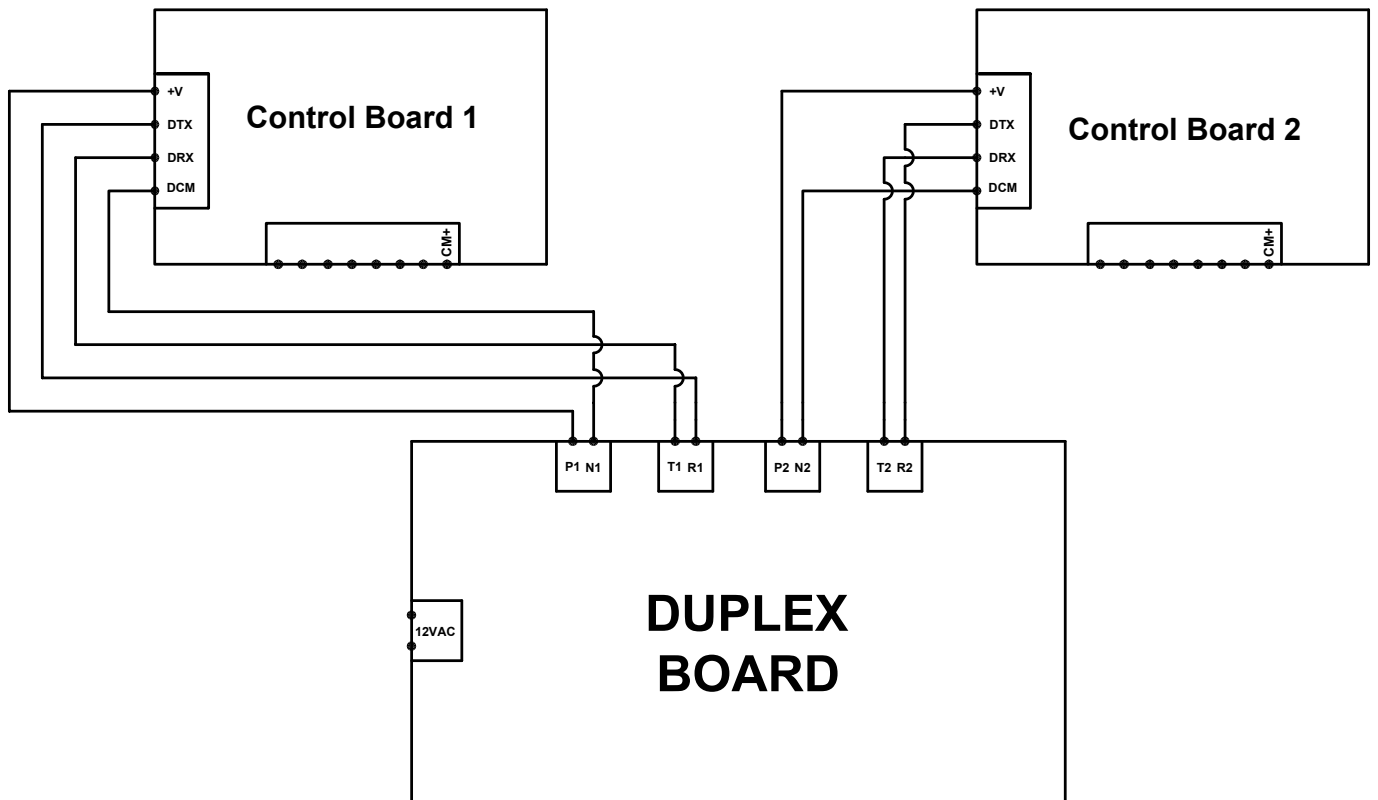

Figure 5.0 - XC-DUP and Control Boards Connections

### 3.3 Landing Calls

The terminals of the Landing Calls are connected as illustrated in Figure 6.0.

- The positive (+) terminal illustrated in Figure 6.0 is used as a +12V DC terminal for the external calls.
- The negative (-) terminal illustrated in Figure 6.0 is used as a common terminal for the external calls.
- For the Selective-Collective call collection type:
  - The terminals of the downward direction external calls are connected from call number 1 to call number 15 on the Down Calls terminals.
  - The terminals of the upward direction external calls are connected from call number 0 to call number 14 on the Up Calls terminals.
- For the Down-Collective call collection type:
  - The terminals of the downward direction external calls are connected from call number 1 to call number 15 on the Down Calls terminals.
  - The terminals of the upward direction external calls are connected to call number 0 on the Up Calls terminal.

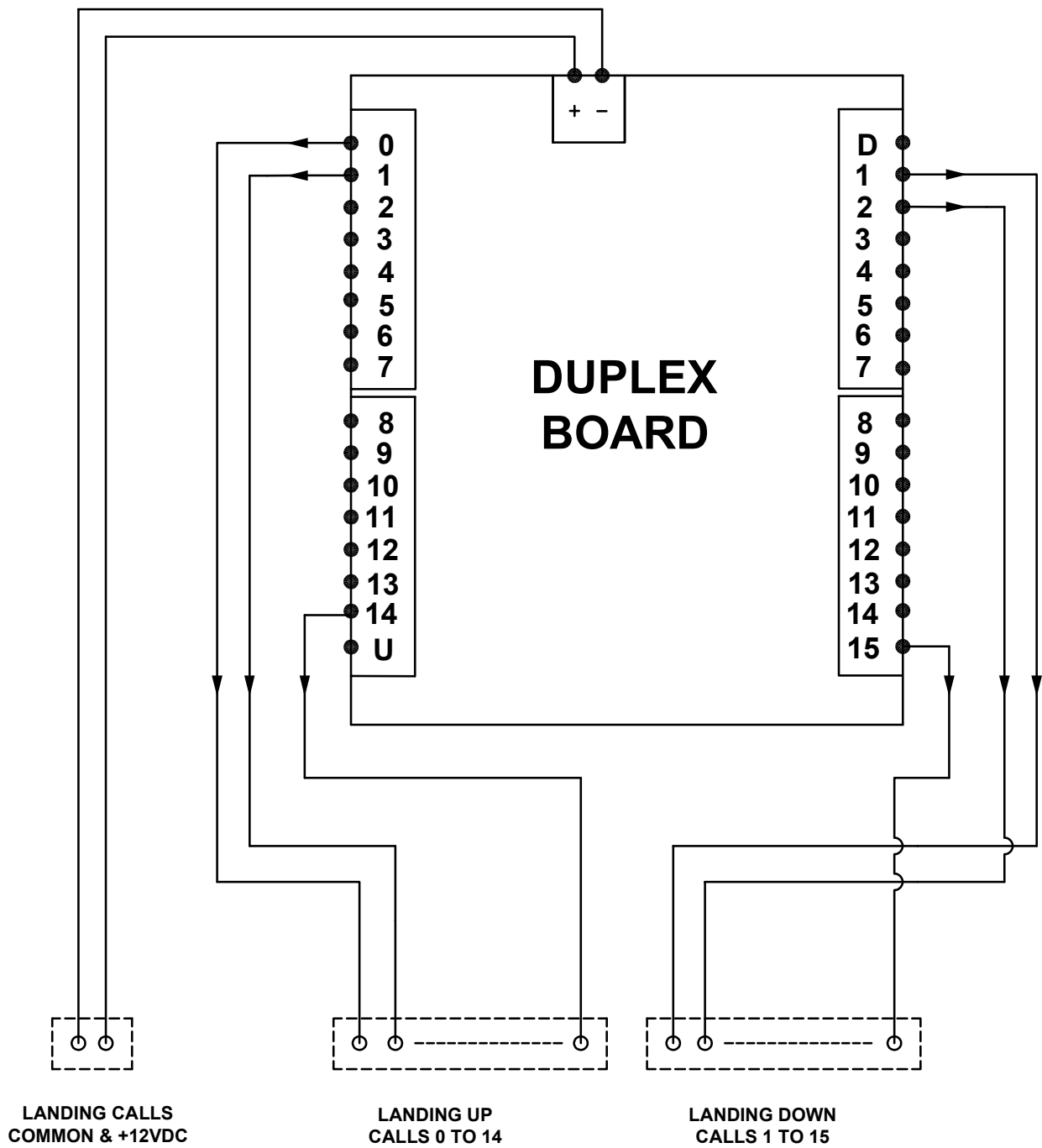

Figure 6.0 - Landing Calls Connections

### 3.4 Car and Shaft

The terminals of the Car and Shaft are connected as illustrated in Figure 7.0.

- The Car and Shaft terminals (CN12) are responsible for the selector magnet switches, the floor level magnetic switches, the direction limit switches, the inspection terminal, the overweight terminal, the full weight terminal, the fire unit terminal, the car priority switch, and the safety circuit terminals, which include: the stop, the slip, the fork, and the lock terminals.
- The Car and Shaft terminals (CN12) are different in contact connections, either NO (Normally Open) or NC (Normally Closed), whether the connections are direct to the XC-DUP series or indirect through an external relay as illustrated in Figure 7.0.
- The Car and Shaft terminals (CN12) are supplied from the CM+ terminal CN12 with XC-DUP-8 & CN9 with XC-DUP-GL.

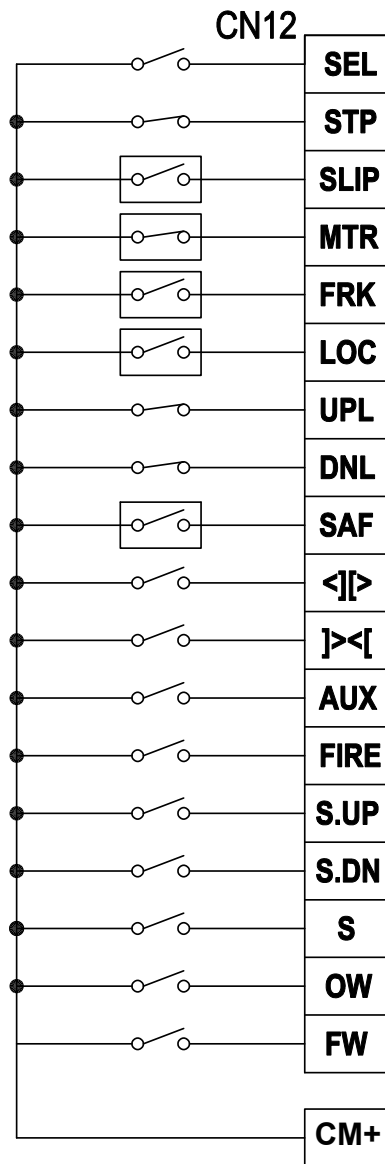
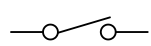
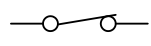
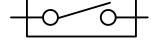
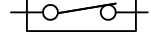

Figure 7.0 - Car and Shaft Connections

Note:

-  Directly connected NO contact
-  Directly connected NC contact
-  Indirectly connected NO contact via relay
-  Indirectly connected NC contact via relay

### 3.4.1 SEL

The SEL terminal (CN12) is responsible for the counter operation and the speed switching from the fast to the slow speed in the XC-DUP series. The SEL terminal (CN12) is directly connected to its assigned magnetic switch, a NO (Normally Open) switch, which switches states according to the detected magnetic elevator strips installed in the shaft, enabling the counter to increment or decrement according to the direction of motion. The incrementation and decrementation process is viewed on the LCD control board screen.

#### Note:

Each floor is assigned two magnetic elevator strips for the appropriate magnetic switch, which are recognized and counted by the program. The selector magnetic switch is responsible for switching the car's speed, from fast to slow.

### 3.4.2 STP

The STP terminal (CN12) is responsible for stopping the car at its desired floor level. The STP terminal (CN12) is directly connected to its assigned magnetic switch, a NC (Normally Closed) switch, which switches states according to the detected magnetic elevator strips installed in the shaft.

#### Note:

Each floor is assigned one magnetic elevator strip for the appropriate magnetic switch. The magnetic elevator strip installed in the shaft should be placed in a suitable position so that the level of the car is well-aligned with the level of the floor.

### 3.4.3 SLIP

The SLIP terminal (CN12) is responsible for safely operating the car in its optimum range of operation through an external device. The SLIP (CN12) terminal is indirectly connected to the NC (Normally Closed) over travel limit switches at the upward and downward limits of the car's vertical range of operation in the shaft, through an external relay. The connections of the SLIP terminal (CN12) are furtherly illustrated in Figure 28.0.

### 3.4.4 MTR

The MTR (Motor overcurrent) terminal (CN12) is responsible for detecting the motor overcurrent signal through an external device. The MTR terminal (CN12) is directly connected to the NC (Normally Closed) contact terminals of the respective fast speed overload and slow speed overload. The series connections present for the MTR terminal (CN12) is illustrated in Figure 9.0 It should be connected to CM+, if it is not used.

Note:

In case of a resulting overcurrent in the motor, the car continues its motion and stops on the nearest floor to safely evacuate passengers.

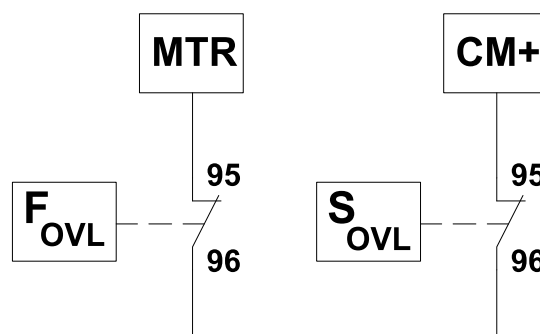

Figure 8.0 - MTR Connections

### 3.4.5 FRK

The FRK terminal (CN12) is responsible for the safe operations of the floor door contacts. The FRK terminal (CN12) is connected to the door contacts of each floor, through an external relay. The connections of the FRK terminal (CN12) are furtherly illustrated in Figure 28.0.

### 3.4.6 LOC

This LOC terminal (CN12) is responsible for the safe operations of the floor door lock contacts. The LOC terminal (CN12) is connected to the door lock contacts of each floor, through an external relay. The connections of the LOC terminal (CN12) are furtherly illustrated in Figure 28.0.

### 3.4.7 UPL

The UPL terminal (CN12) is responsible for speed switching on the uppermost floor. The UPL terminal (CN12) is directly connected to it's assigned NC (Normally Closed) up-limit switch in the shaft.

### 3.4.8 DNL

The DNL terminal (CN12) is responsible for the speed switching on the ground floor. The DNL terminal (CN12) is directly connected to it's assigned NC (Normally Closed) up-limit switch in the shaft.



### 3.4.9 SAF

The SAF terminal (CN12) is responsible for stopping the car due to an action performed from the over-speed governor, the inspection box stop, the car emergency stop, the pit stop, and the car buffer. The SAF terminal (CN12) is connected to the NC (Normally Closed) contacts of the safety stop circuits mentioned, through an external relay. The connections of the SAF terminal (CN12) are furtherly illustrated in Figure 28.0.

### 3.4.10 <][>

The '<][>' terminal (CN12) is responsible for the fast opening of the car's automatic door. The '<][>' terminal (CN12) is connected to the NO (Normally Open) contacts of the push buttons of the COP (Car Operating Panel).

Note:

This terminal only operates if the car is on the same level as the floor and the door type installed is automatic.

### 3.4.11 ]<>[

The ']<>[' terminal (CN12) is responsible for the fast closing of the car's automatic door. The ']<>[' terminal (CN12) is connected to the NO (Normally Open) contacts of the push buttons of the COP (Car Operating Panel).

Note:

This terminal only operates if the car is on the same level as the floor and the door type installed is automatic.

### 3.4.12 AUX

The AUX terminal (CN12) is responsible for the VIP (Car Priority) operations, assigning the car to fulfill a single call at a time and cancel all registered calls. The AUX terminal (CN12) is directly connected to the NO (Normally Open) contacts of the push button of the COP (Car Operating Panel).

The methods for operation of the AUX terminal (CN12) are explained in the following section.

- When the AUX terminal (CN12) is activated (AUX = ON) during car execution of the registered calls, the elevator stops at the first registered floor after the first registered call is executed, while the rest of the registered calls are canceled and wait for registration of the desired floor.
- In the case that the AUX terminal (CN12) is activated (AUX = ON) and the car is present on a floor, the car waits for the registration of the car priority call and moves towards its direction immediately.
- In case of unregistered calls and an automatic door type, the door remains open until further action is required.
- When the AUX terminal (CN12) is deactivated (AUX = OFF), the car restores its normal mode of operation.

### 3.4.13 FIRE

The FIRE terminal (CN12) is responsible for determining the default action provided by the XC-DUP series according to the action of the external fire alarm unit. In case of fire hazards, the car will immediately move to the assigned fire floor. The FIRE terminal (CN12) is directly connected to the NO (Normally Open) contacts of an external fire alarm unit if present.

The methods for operation of the FIRE terminal (CN12), Program P23: Fire Man (Section 5.10) are explained in the following section.

- When the car moves in the direction of the programmed fire floor, all the registered car calls are canceled and the car will continue to move to its defined floor.
- If the car moves in the opposite direction of the programmed fire floor, all the registered car calls are canceled and the motion speed is switched to slow and the car will move for four seconds and stop shortly after. Afterwards, the car will then move to its defined floor.

### 3.4.14 SERVICE

The SERVICE terminals (CN12) are responsible for enabling the operator to move the car in the inspection mode using the following three terminals S, UP, and DN. The S terminal (CN12) is connected to the inspection selector switch in the inspection box. The UP terminal (CN12) is connected to the UP NO (Normally Open) push button in the inspection box to move the car in the upward direction. The DN terminal (CN12) is connected to the DOWN NO (Normally Open) push button in the inspection box to move the car in the downward direction.

### 3.4.15 OW

The OW (Overweight) terminal (CN12) is responsible for ensuring the car remains idle in case of excessive weight in the car. The OW (Overweight) terminal (CN12) is connected to the NO (Normally Open) terminal of the overweight signal in the weight detection device as illustrated in Figure 10.0.

Note:

The OW (Overweight) signal in the car is activated until the required weight of the car is in the appropriate range of operation, once the OW (Overweight) signal is deactivated, the car regains its normal operation conditions.

### 3.4.16 FW

The FW (Full Weight) terminal (CN12) is responsible for ensuring the car lands on the requested car calls and denies external calls, until the required weight in the car is in the appropriate range of operation. The FW (Full Weight) terminal (CN12) is connected to the NO (Normally Open) terminal of the full weight signal in the weight detection device as illustrated in Figure 9.0.

Note:

The FW (Full Weight) signal in the car is activated until the required weight of the car is in the appropriate range of operation, once the FW (Full Weight) signal is deactivated, the car is ready to execute external call requests again.

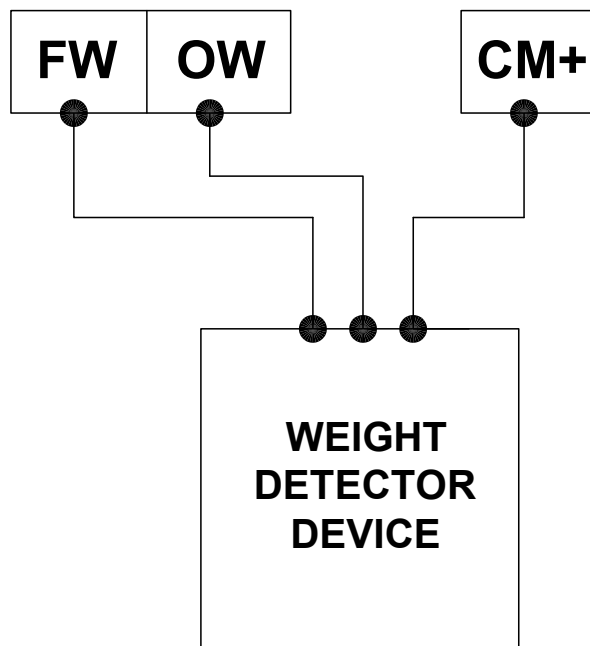

Figure 9.0 - Weight Signal Connections

### 3.5 7-Segment Indicator

The terminals of the 7-Segment Indicator are connected as illustrated in Figure 10.0.

- The positive terminal of the 7-Segment Indicator (+12V) is connected to the positive terminal of the external bridge (+12V).
- Terminals A, B, C, D, E, F, G and H of the 7-Segment Indicator are connected to the replicate lettered terminals (CN10) on the XC-DUP series.
- It is recommended to connect the negative terminal of the external bridge (-12V) to the GND terminal (CN9) of the XC-DUP series.

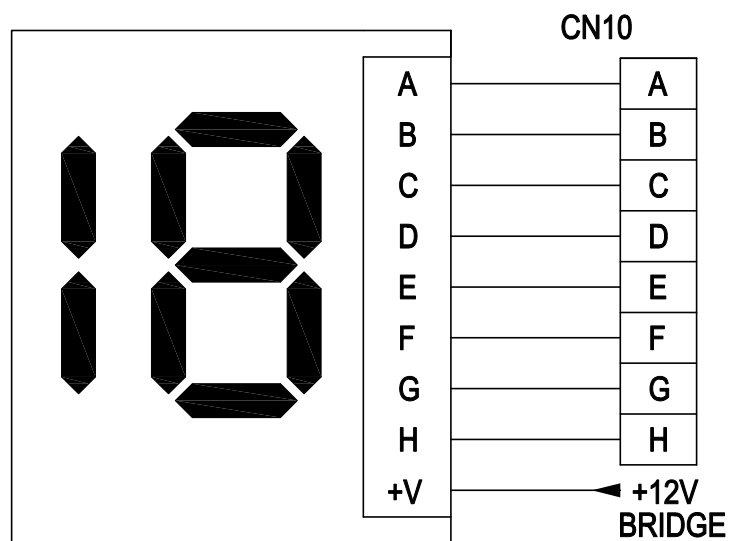

Figure 10.0 - 7-Segment Indicator Connections

### 3.6 Floor Wire Indicator

The terminals of the Floor Wire Indicator are connected as illustrated in Figure 11.0 for a maximum of eight stops.

- The positive terminal of the Floor Wire Indicator (+12V) is connected to the positive terminal of the external bridge (+12V).
- Terminals A, B, C, D, E, F, G and H of the Floor Wire Indicator are connected to the replicate lettered terminals (CN10) on the XC-DUP series.
- In case the number of stops exceed eight stops and are up to twelve stops, the number of displays can be extended to accommodate twelve displays using the extension board (XE-1) through the following steps:
  - Internal call terminals from (0-3) on the extension board are used as car calls for stops from (9-12).
  - External call terminals from (0-3) on the extension board are used as landing calls for stops from (9-12).
  - Internal call terminals from (4-7) on the extension board (XE-1) are used as Floor Wire Indicator terminals for stops from (9-12).
- It is recommended to connect the negative terminal of the bridge (-12V) to the GND terminal (CN9) of the XC-DUP series.

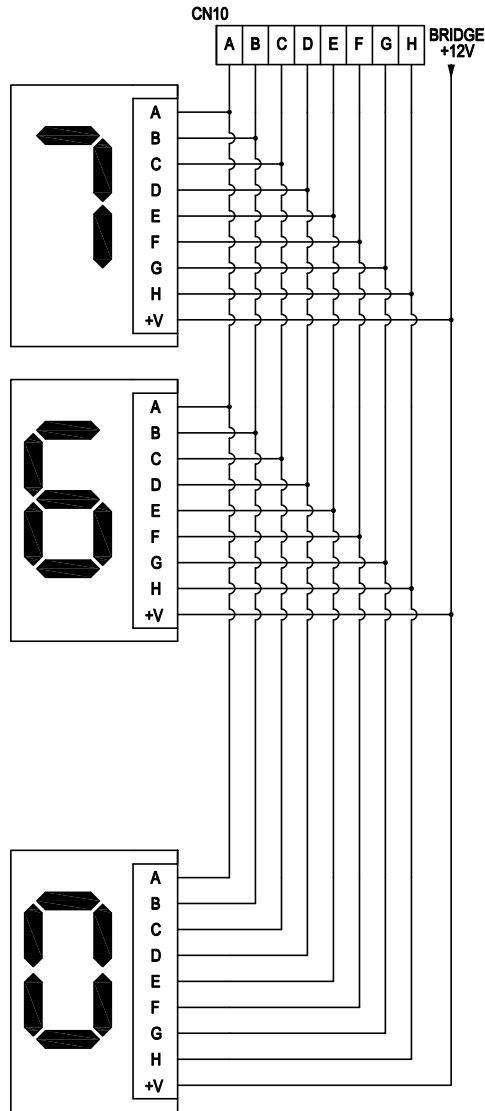

Figure 11.0 - Floor Wire Indicator Connections



### 3.7 Car Calls

The Car (Internal) Call terminals are connected as illustrated in Figure 12.0.

- The first terminal of the CPBB (Car Push Button Bulb) is connected to the positive terminal of the external bridge (+12V).
- The second terminal of the CPBB (Car Push Button Bulb) should be connected to the call terminal (CN7) on the XC-DUP series with one terminal of the CPBC (Car Push Button Contact).
- The second terminal of the CPBC (Car Push Button Contact) is connected to the COM terminal (CN9) on the XC-DUP series.
- It is recommended to connect the negative terminal of the external bridge (-12V) to the GND terminal (CN9) of the XC-DUP series.
- It is recommended to use a 1A diode between the CPBB (Car Push Button Bulb) and the CPBC (Car Push Button Contact) to avoid dim lighting on push button call, caused by cable noise.

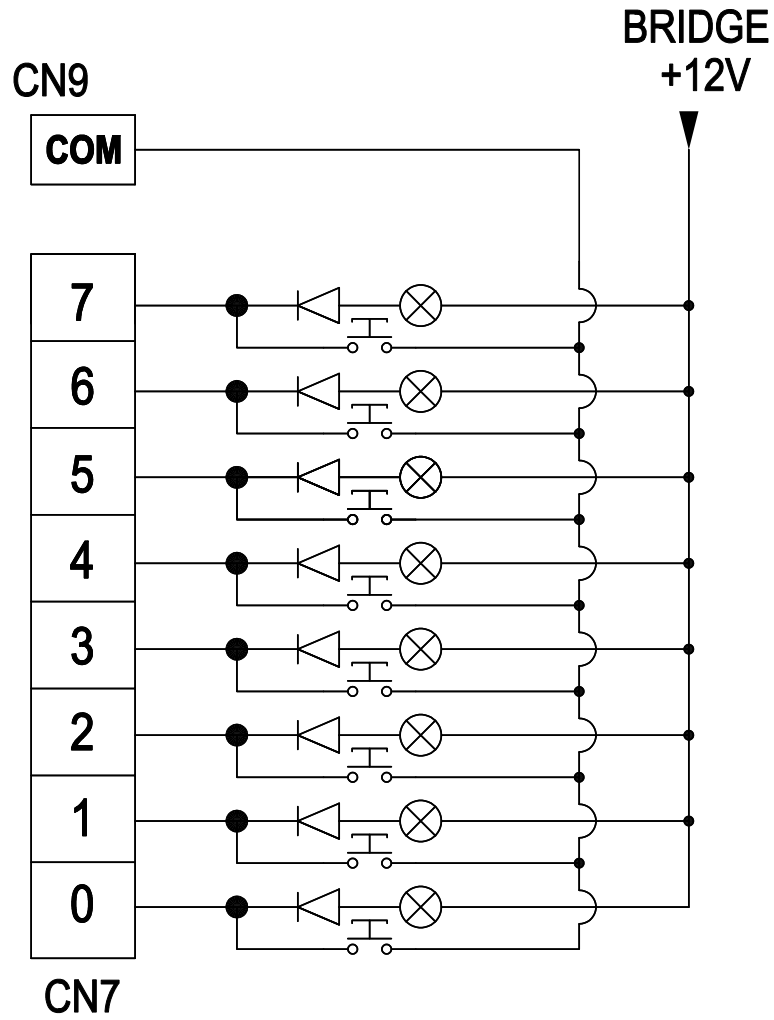

Figure 12.0 - Car Call Connections

### 3.8 Arrow Signals

The terminals of the Arrows (up and down) are connected as illustrated in Figure 13.0.

a) For the XC-DUP-8 Sub-Series:

- Figure 13.0 illustrates the installation and wiring of the Arrow Signals in case of not applying the hydraulic functionality.
- The HYD terminal (CN6) is connected to the negative terminal of the external bridge (-12V).
- The STR (CN6) terminal is connected to the first terminal of the UP Arrow LED and the second terminal is connected to the positive external bridge terminal (+12V).
- The DEL (CN6) terminal is connected to the first terminal of the DOWN Arrow LED and the second terminal is connected to the positive external bridge terminal (+12V).

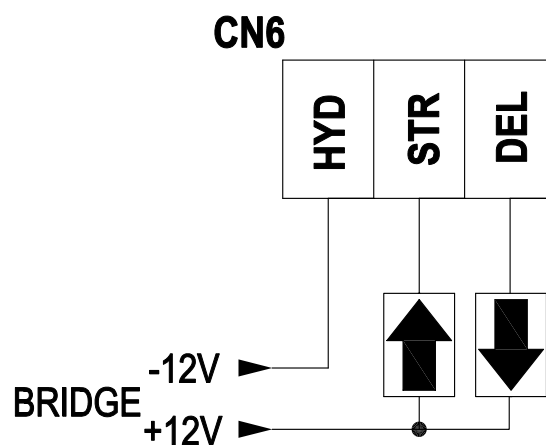

Figure 13.0 -XC-DUP-8 Arrow Signals Connections

**b) For the XC-DUP-GL Sub-Series:**

The terminals of the Arrows (Up and Down) are connected as illustrated in Figure 14.0.

- Figure 14.0 illustrates the installation and wiring of the Arrow Signals.
- The ARC terminal (CN13) is connected to the negative terminal of the external bridge (-12V).
- The AU terminal (CN13) is connected to the first terminal of the Up Arrow LED and the second terminal is connected to the positive external bridge terminal (+12V).
- The AD terminal (CN13) is connected to the first terminal of the Down Arrow LED and the second terminal is connected to the positive external bridge terminal (+12V).

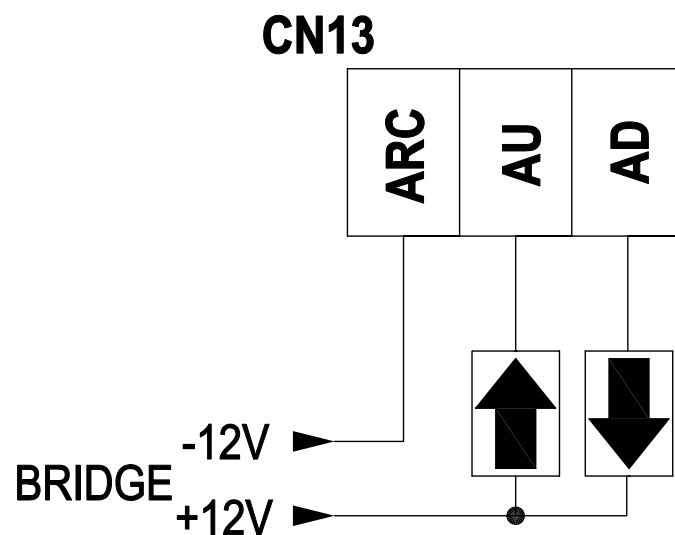

Figure 14.0 -XC-DUP-GL Arrow Signals Connections

### 3.9 Gong Signals

The terminals of the Gong Signals (Fast and Slow) are connected as illustrated in Figure 15.0.

- The ANC terminal (CN15 with XC-DUP-8 /CN14 with XC-DUP-GL) is connected to the negative terminal of the bridge (-12V).
- The A.FT terminal (CN15/CN14) is connected to the first terminal of the Fast Gong and the second terminal is connected to the positive terminal of the external bridge (+12V).
- The A.SL terminal (CN15/CN14) is connected to the first terminal of the Slow Gong and the second terminal is connected to the positive terminal of the external bridge (+12V).

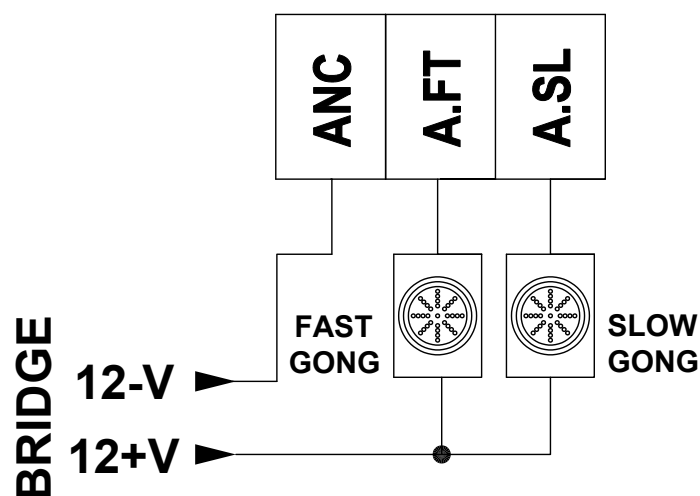

Figure 15.0 - Gong Signal Connections

### 3.10 Manual Doors

The Manual Door operating terminals are wired and connected as illustrated in Figure 16.0.

- The CAM terminal (CN3) is responsible for operating the doors.
- For Manual Doors operating through a Retiring CAM, the external CAM contactor is connected to the XC-DUP series as illustrated in Figure 16.0.
- The Retiring CAM is operated by the DC voltage of the external bridge through the contactor as illustrated in Figure 16.0.

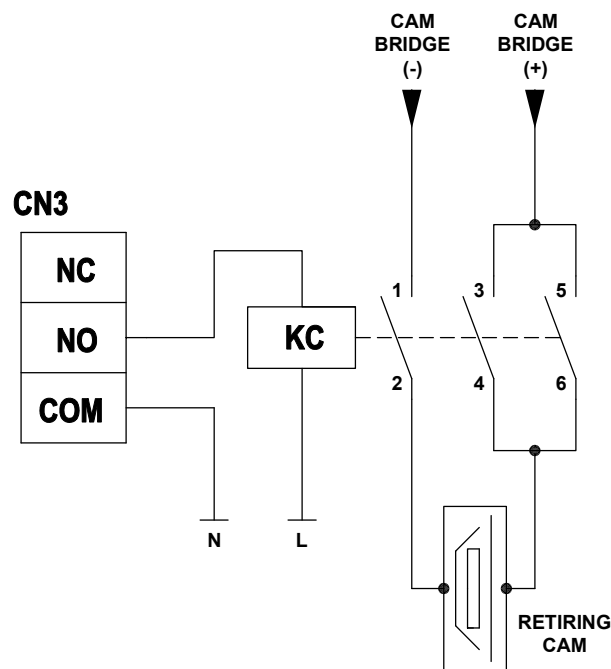

Figure 16.0 - Manual Door Connections

### 3.11 Three-Phase Automatic Doors

The terminals of operating the Three-Phase Automatic Door are wired and connected as illustrated in Figure 17.0.

- Operating the Three-Phase Automatic Door requires two contactors for opening and closing.
- The Normally Open (NO) terminal (CN3) is responsible for closing the Three-Phase Automatic Door.
- The Normally Closed (NC) terminal (CN3) is responsible for opening the Three-Phase Automatic Door.
- The terminals of the closing and opening limit switches must be combined into the Three-Phase Automatic Door operation circuit as illustrated in Figure 17.0.

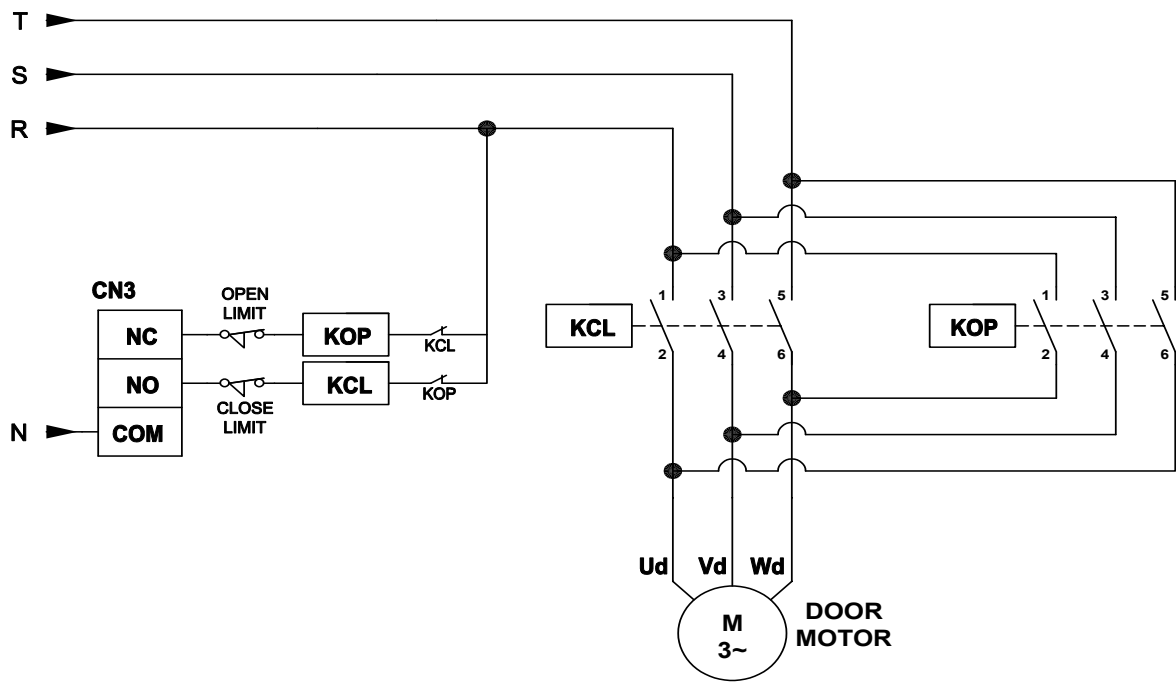

Figure 17.0 - Three-Phase Automatic Door Connections

### 3.12 Single-Phase Automatic Doors

The terminals of operating the Three-Phase Automatic Door are wired and connected as illustrated in Figure 18.0.

- The Single-Phase Automatic Door signals are connected to the terminals of the CAM connector (CN3) in the XC-DUP series as the following:
- The Normally Open (NO) terminal (CN3) is connected to the Single-Phase Automatic Door closing signal.
- The Normally Closed (NC) terminal (CN3) is connected to the Single-Phase Automatic Door opening signal.
- The COM signal of the Single-Phase Automatic Door is connected to the CAM relay COM (CN3) of the XC-DUP series.

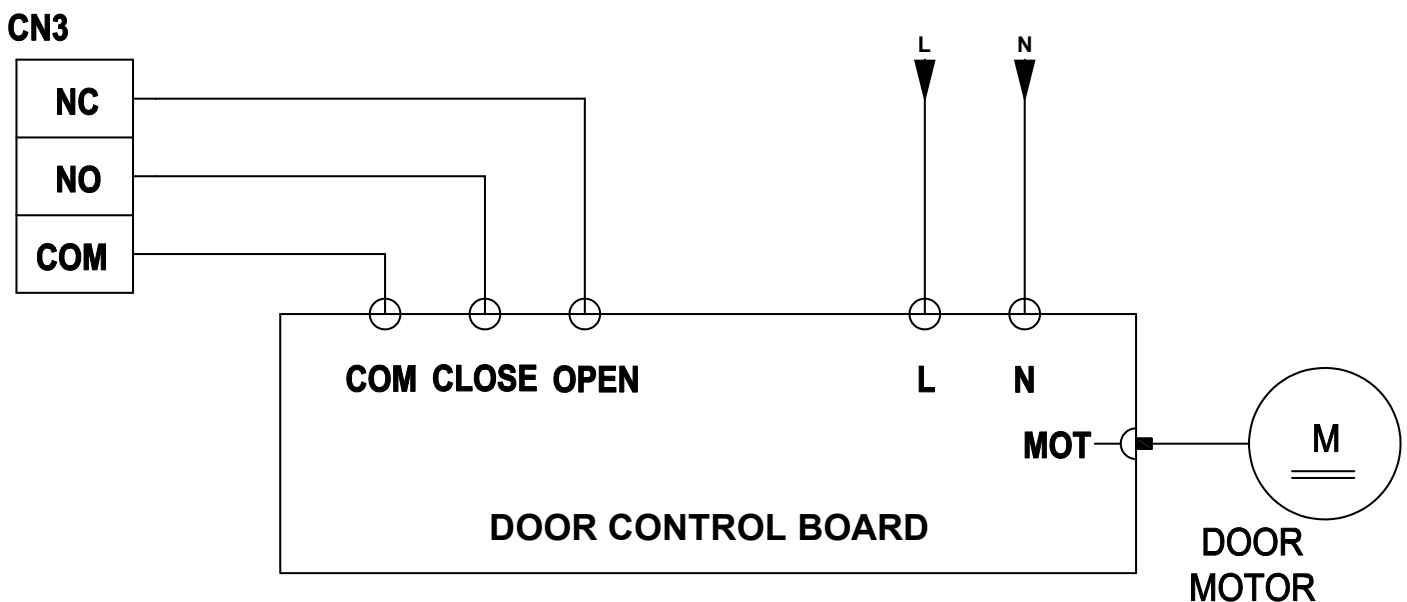

Figure 18.0 - Single-Phase Automatic Door Connections



### 3.13 Single-Phase Semi-Automatic Doors

#### a) For the XC-DUP-8 Sub-Series:

- The CAM connector (CN3) is used to connect the Single-Phase Semi-Automatic Door, using the same connections described in section 3.13.
- HYD and STR terminals (CN6) in the hydraulic connector are used to connect the Retiring CAM contactor using the same connections described in section 3.11, in this case the arrows do not connect on the XC-DUP.

#### b) For the XC-DUP-8GL Sub-Series:

The terminals of operating the single phase Semi-Automatic Door are wired and connected as illustrated in Figure 19.0.

- In this case, the door is considered as a Manual Door, therefore the CAM terminal (CN3) is connected as illustrated in Figure 19.0.
- A 12V DC relay should be in use. Moreover, the CAM contactor must have NC (Normally Closed) and NO (Normally Open) contacts.

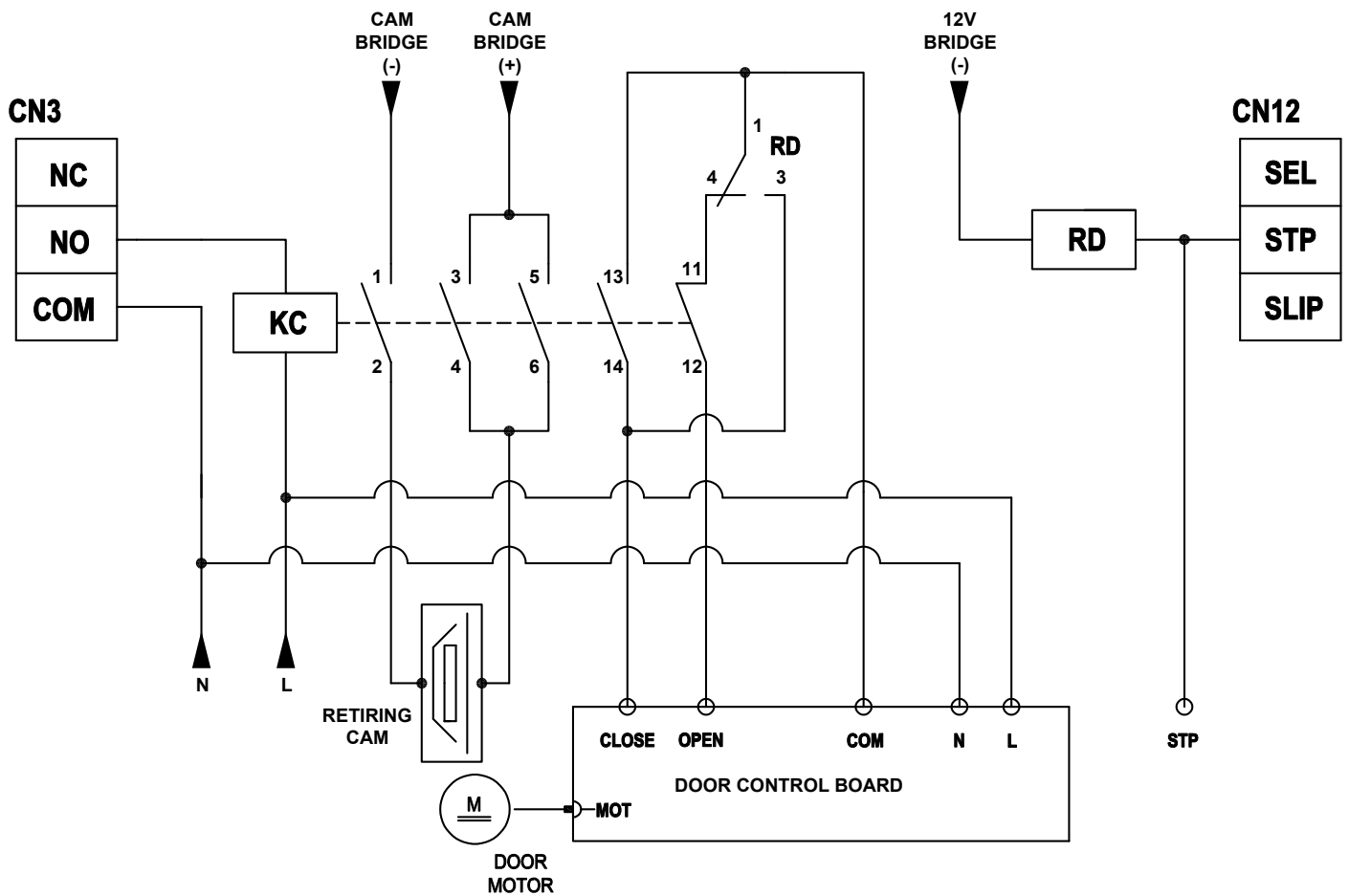

Figure 19.0 - Single-Phase Semi-Automatic Door Connections

### 3.14 Inverter Motion Signals and Power Supply

The terminals of the Inverter Motion Signals and Power Supply are connected as illustrated in Figure 20.0.

Note:

The Inverter Motion signals and Power Supply installation and connections are only available for the XC-DUP-GL sub-series.

- The operation of the inverter is controlled either through the selection of the three-phase power supply or the emergency UPS device, based on the actions taken by the board according to phase failure status and indications illustrated in Figure 20.0.
- The Motion signal terminal (CN4) of the XC-GL series board is connected to the appropriate terminal of the inverter.
- The EMR terminal (CN4) of the XC-GL series board is connected to the appropriate emergency input of the inverter.
- Figure 20.0 illustrates the connection of the XC-GL series board with the inverter, the UPS device, the machine motor, and the braking system.

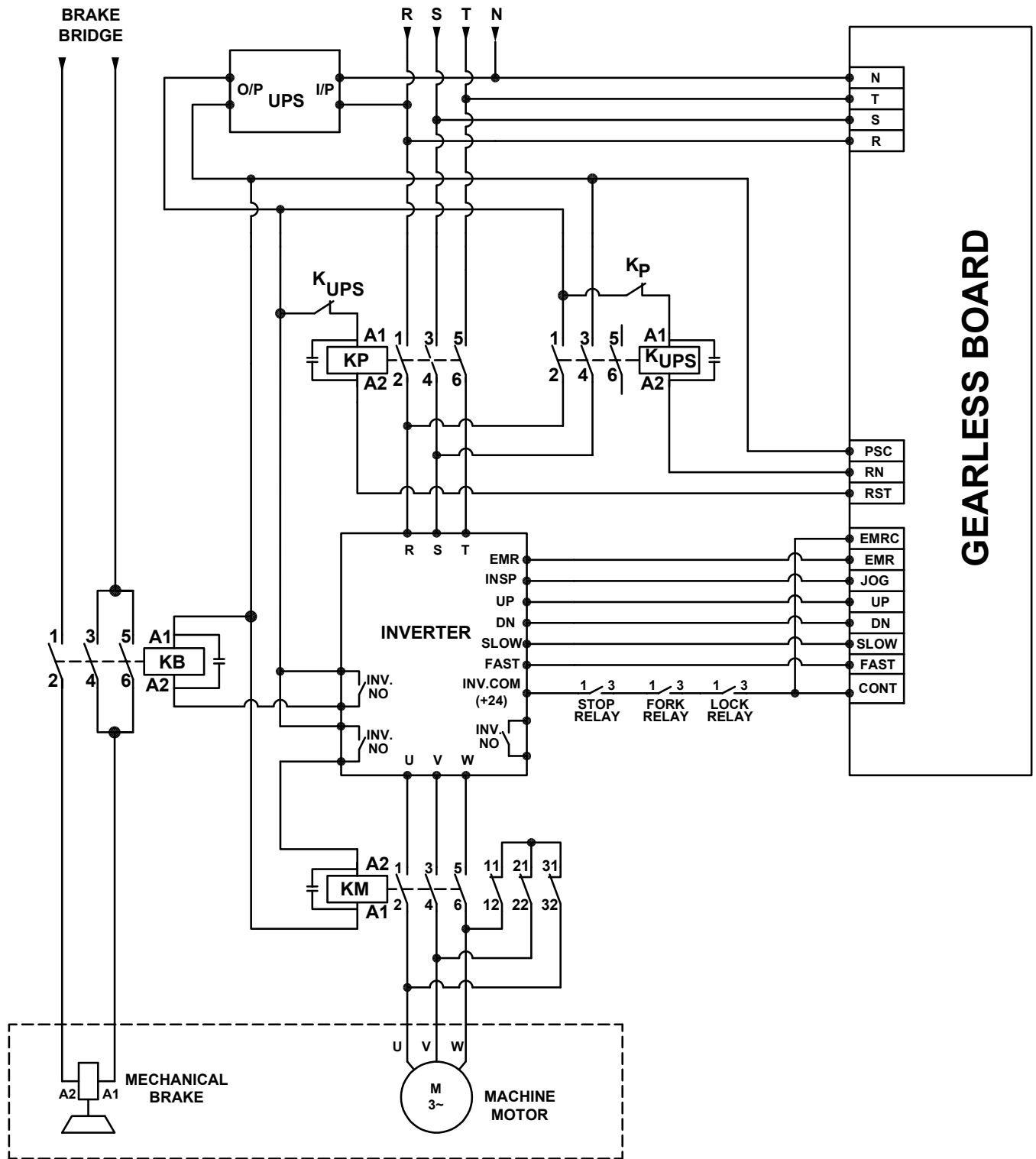

Figure 20.0 - Inverter Motion Signals and Power Supply Connections

### 3.15 Two-Speed Systems

The terminals of operating the Two-Speed System with contactors are wired and connected as illustrated in Figure 21.0.

Note:

The Two-Speed Systems' installation and connections are only available for the XC-DUP-8 sub-series.

- The motion signal terminal (CN4) is connected as illustrated in Figure 21.0.
- The Up and Down relays on the board are electrically interlocked ensuring safe direction switching in case of failure.
- The CONT terminal (CN4) should be cut off through NO (Normally Open) contacts in the safety circuits relays before connecting it to the other terminal of the contactors coil supply, so that the car can't move unless the safety circuits are completed.
- For more safety, there is an external electrical interlock between Up and Down contactors as illustrated in Figure 21.0.

Note:

The ceramic capacitor on the coil of the contactors acts as a snubber circuit.

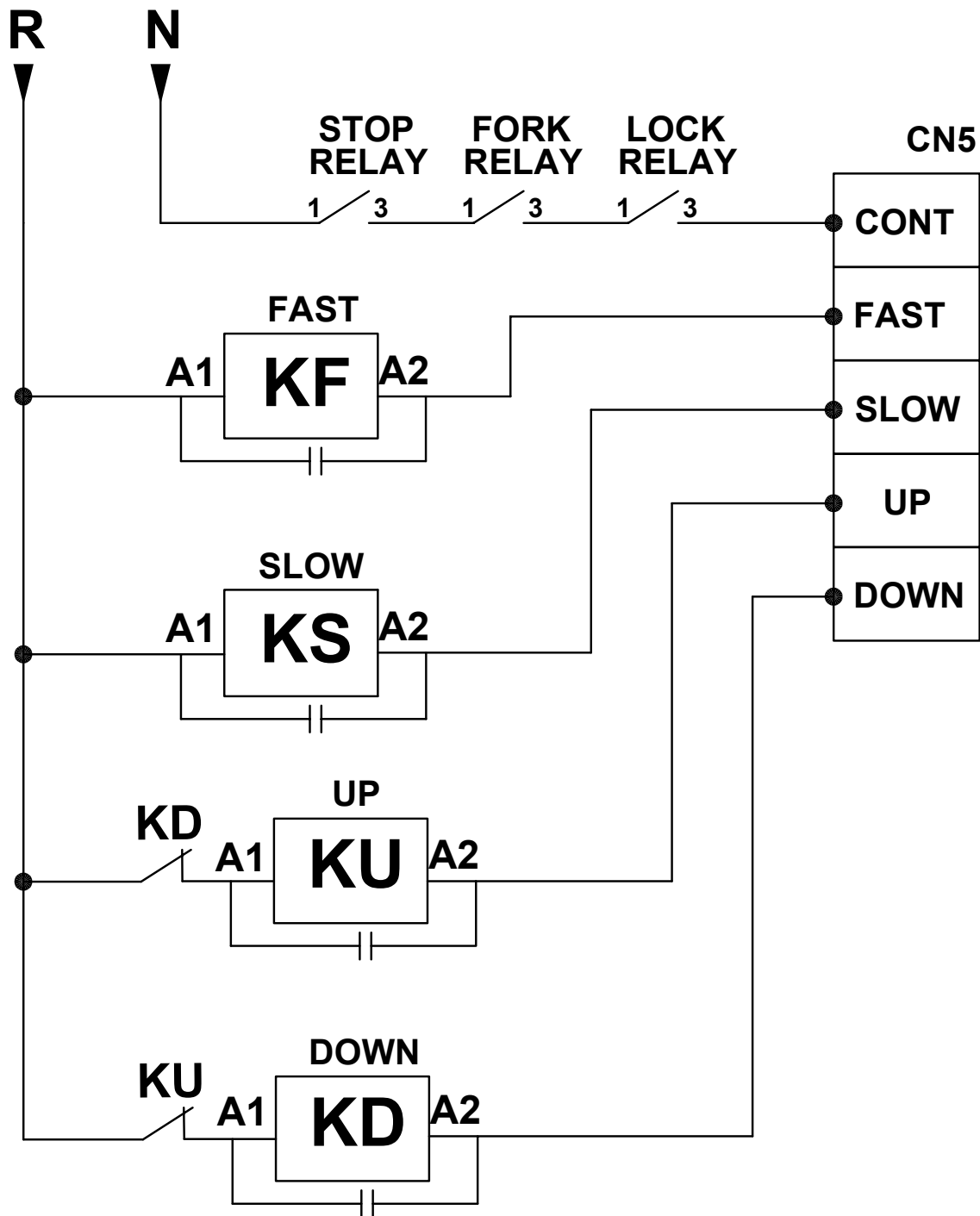

Figure 21.0 - Two-Speed System Connections

### 3.16 Motion Contactors

The terminals of operating the Three-Phase Distribution on the Motion contactors are wired and connected as illustrated in Figure 22.0.

Note:

The Motion Contactors' installation and connections are only available for the XC-DUP-8 sub-series.

- Figure 22.0 illustrates the distribution of the three phases on the motion contactors (Fast, Slow, Up and Down), alongside the method of connection and operation of the system brakes.
- Figure 22.0 represents the condition that the system brake is operated with 75V DC.

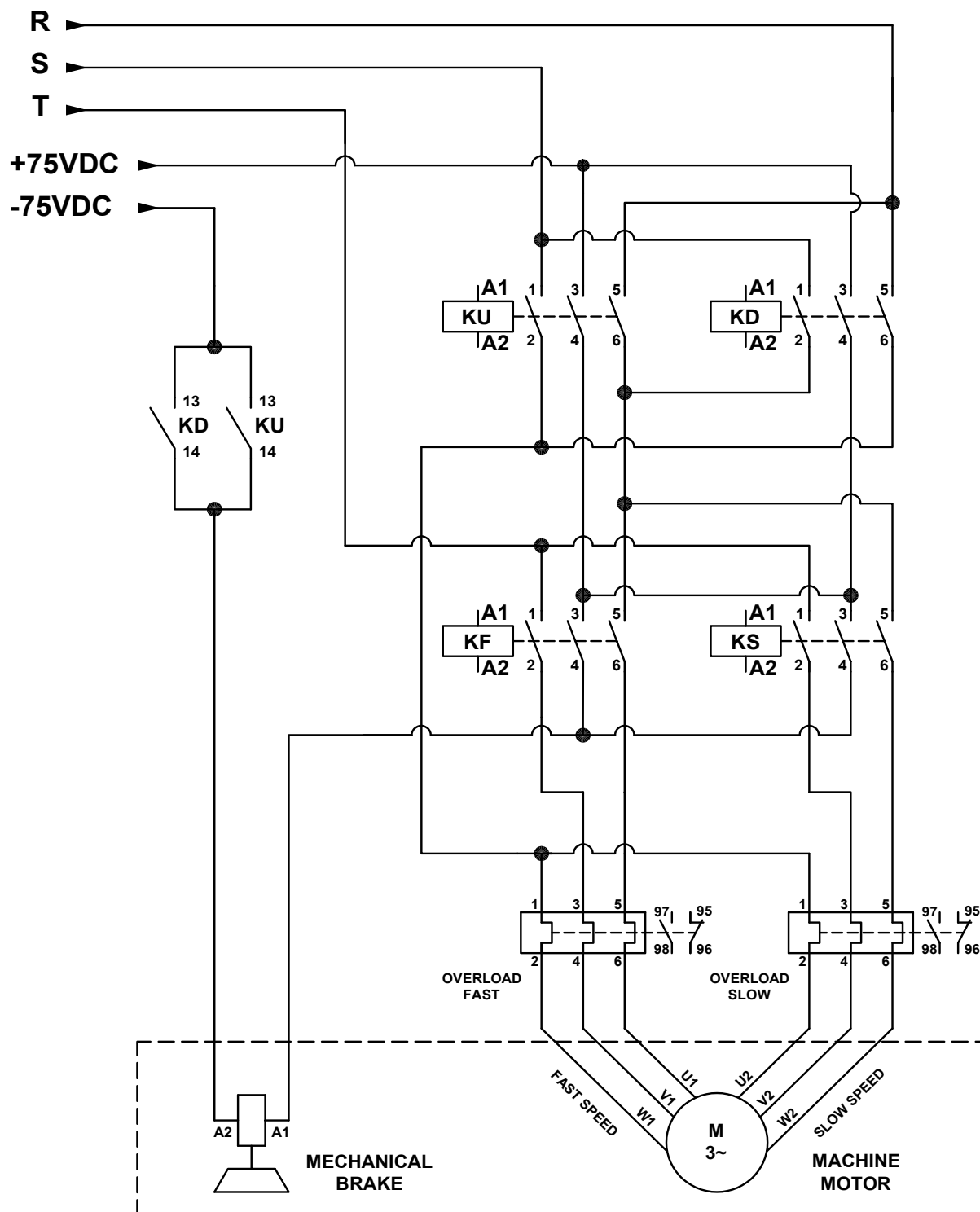

Figure 22.0 - Three-Phase and Brake Connections



### 3.17 Inverter System

The terminals of the Inverter System are connected as illustrated in Figure 23.0.

Note:

The Inverter System’s installation and connections are only available for the XC-DUP-8 sub-series.

- The motor speed and direction signals connector (CN4) are connected as illustrated in Figure 23.0.
- The Up and Down relays on the board are electrically interlocked ensuring safe direction switching in case of failure.
- The CONT terminal (CN4) should be cut off through NO (Normally Open) contacts in the safety circuits relays before connecting it to the inverter common terminal, so that the car can’t move unless the safety circuits are completed.

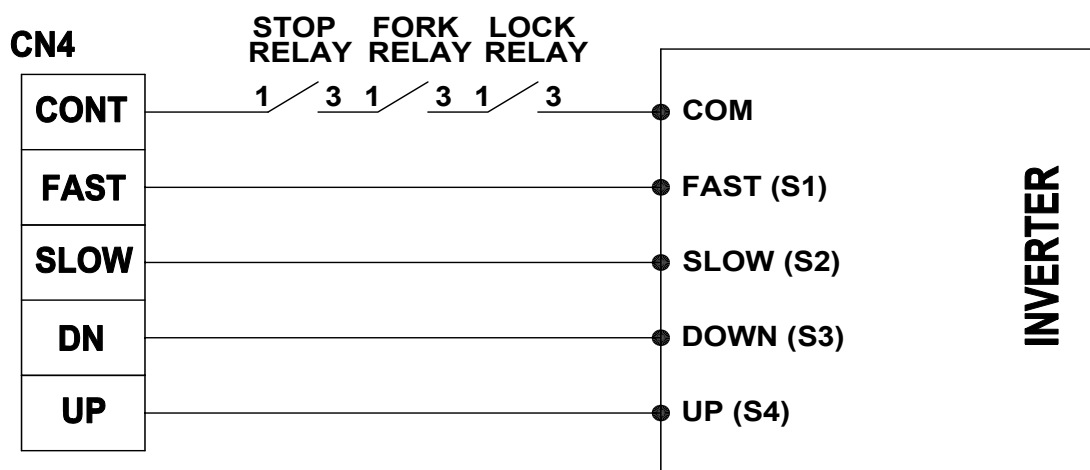

Figure 23.0 - Inverter System Connections

### 3.18 Hydraulic System

Note:

The Hydraulic System’s installation and connections are only available for the XC-DUP-8 sub-series.

The motor speed and direction signals terminal (CN4) is connected as shown in Table 9.0.

UP	Connected to Up Relay
DOWN	Connected to Down Relay
FAST	Connected to VML Relay
SLOW	Connected to Motor Contactor
CONT	Common

**Table9.0 - Motor Speed and Direction Signals**

- The hydraulic connector terminals (CN6) are connected as shown in Table 10.0.

STAR	Star contactor
DELTA	Delta contactor
HYD	Star/Delta contactors common

**Table 10.0 - Hydraulic System Connections**

## A) Operation Scheme:

1. The hydraulic system is selected from the Program P5: System type.
2. The conversion time from STAR to DELTA is adjusted from the Star Time function.
3. The inspection speed is selected, whether fast or slow, from the Hyd Serv function.
4. The 'Relevel' feature is activated from the Relevel function. Relevel means that if the car falls under the floor level (under the floor level magnet) the XC-DUP series moves the car at a slow speed to the UP direction until arriving to the door level again, considering all the safety circuits are closed before the movement and after the lamp time is over.
5. The phases sequence program (Ph. SEQ/FAIL) is adjusted to be (Phase FAIL) or (Phase SEQ + FAIL).
6. At elevator ascension, the relays activated are:

FAST + SLOW + STAR

7. After the conversion time from STAR to DELTA, the STAR relay is stopped and (UP + DELTA) relays activate as the following:

LIGHT + CAM + FAST + SLOW + DELTA + UP

8. After approaching the registered floor, the FAST relay is stopped to be:

LIGHT + CAM + SLOW + DELTA + UP

9. After arriving at the level of the registered floor, the UP relay is stopped, with the car continuing to move for a short period of time to ensure smooth stopping of the movement, which is called SOFT STOP, so the following relays operate:

LIGHT + CAM + SLOW + DELTA

10. At elevator descension, the relays activated are:

LIGHT + CAM + FAST + DOWN

11. After approaching the registered floor, the car continues moving in the slow speed:

LIGHT + CAM + DOWN

12. After arriving at the registered floor, the CAM and DOWN relays are stopped.

13. The up and down relays are electrically interlocked ensuring safe direction switching in case of failure.

B) Wiring Diagram:

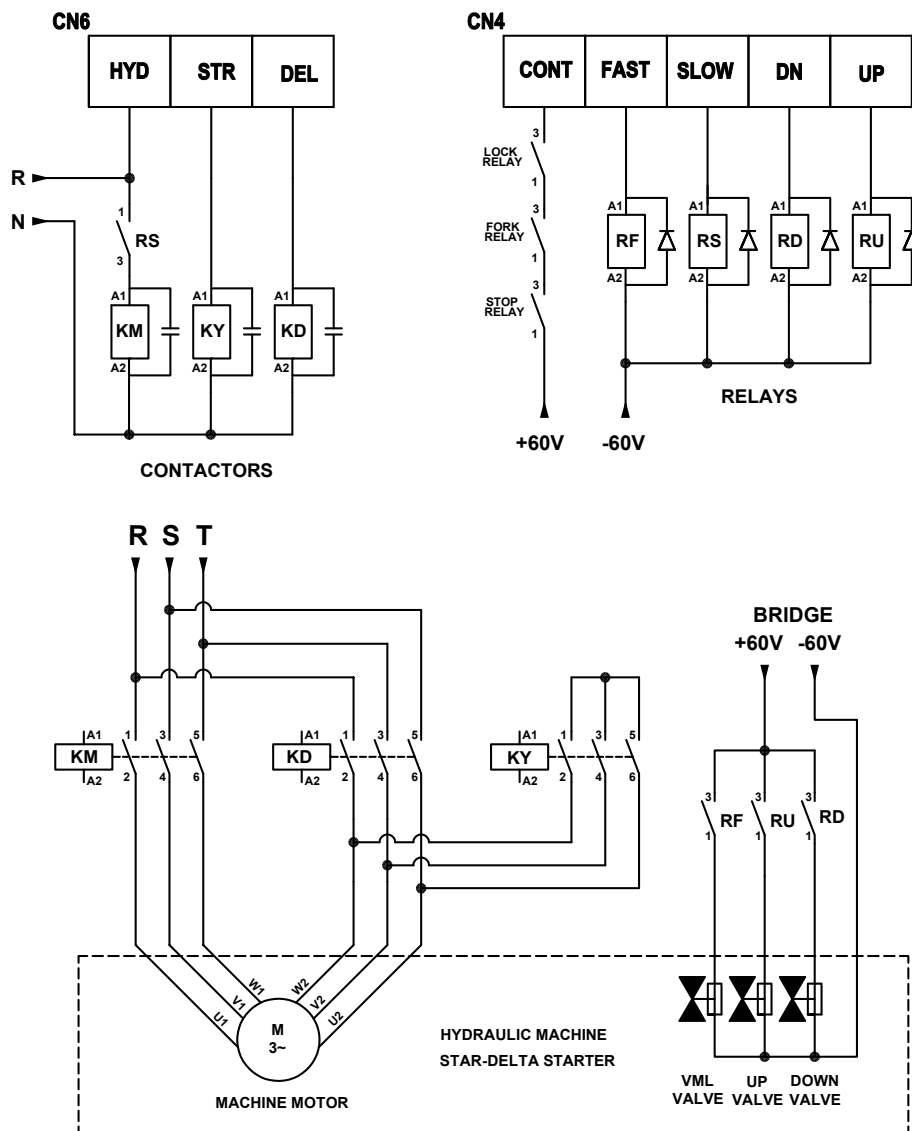

Figure 24.0 - Hydraulic System Wiring

Note:

The Gong Signals terminal (CN15) can't be used, but in this case the fast and slow gong signals should be connected as illustrated in Figure 25.0.

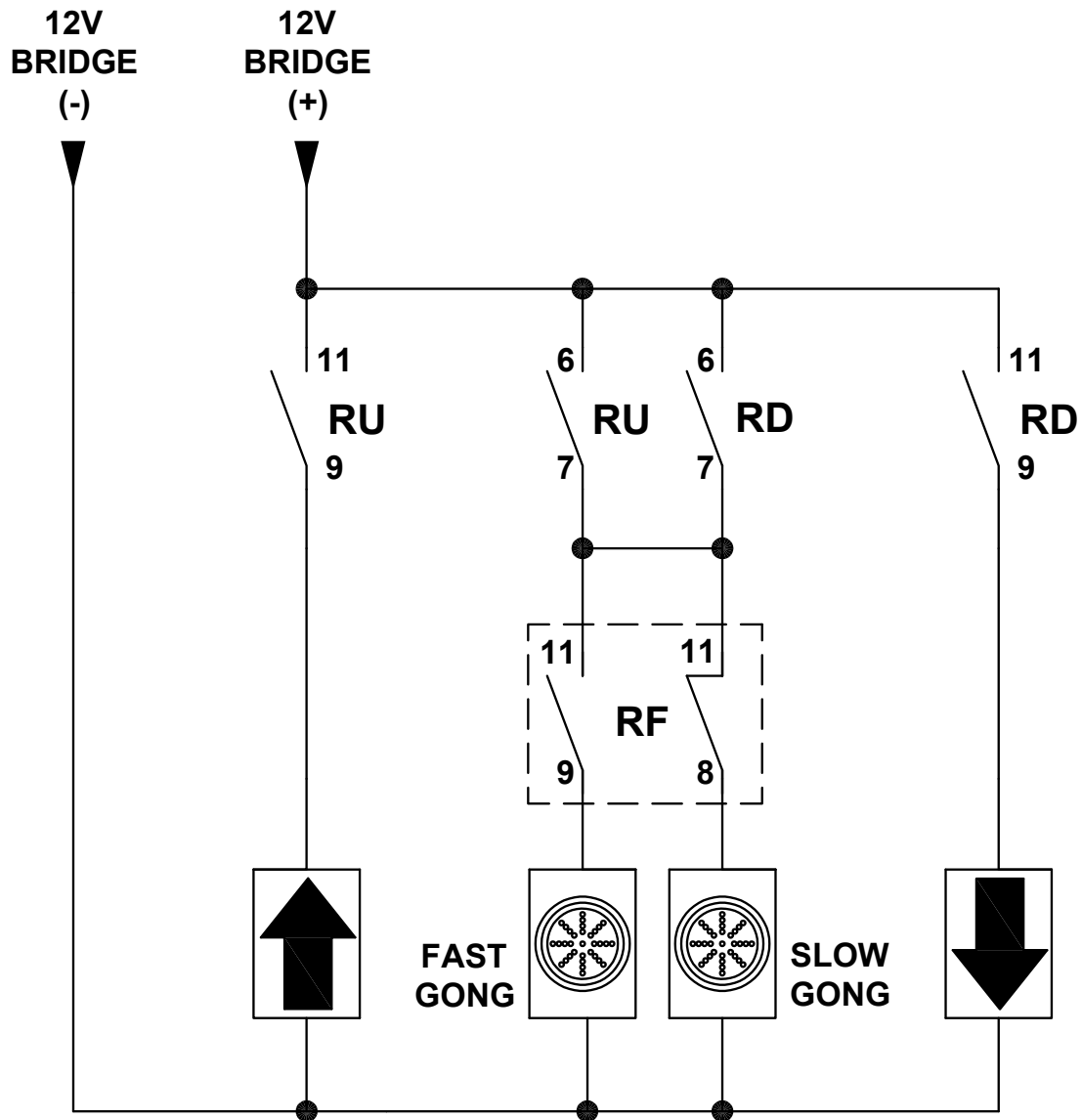

Figure 25.0 - Gong Signal Connections in the Hydraulic System

### 3.19 Safety Circuits

The terminals of the Safety Circuits are connected as illustrated in Figure 26.0.

- Figure 26.0 represents a guide for connecting Safety Circuits to the shaft terminals (CN12) on the XC-DUP series board.
- The Safety Circuits are operated with 60V DC using an external relay as illustrated in Figure 26.0.
- A series connection is recommended in the following order: +60V DC, Stop Circuit, Slip Circuit, Door contacts, and Door Locks contacts respectively. This will disable elevator operation in case of malfunction or failure in any of the mentioned circuits.
- Figure 26.0 represents the condition when all safety circuits are closed, where the car can operate normally.

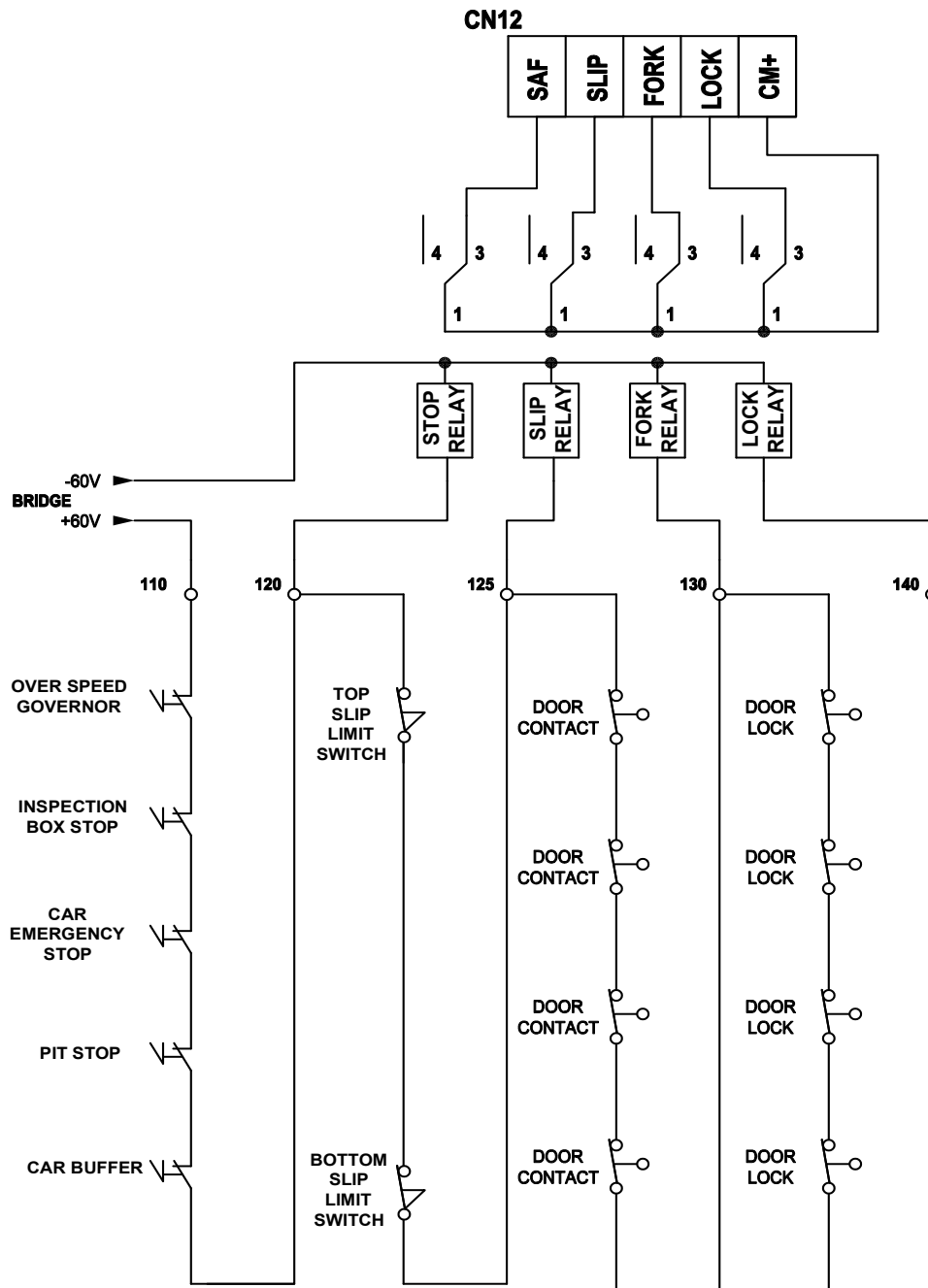

Figure 26.0 - Safety Circuit Connections



### 3.20 Magnetic Configuration

Figure 27.0 illustrates the configuration of the magnetic slide positions with the floor levels, according to the position of the selector and the level magnet.

- Speed switching from FAST to SLOW is done through the selector magnet switch and its magnetic slides for all of the floors except the ground and the last stop.
- Speed switching in the ground and the last stop are done through the Up and Down limit switches.

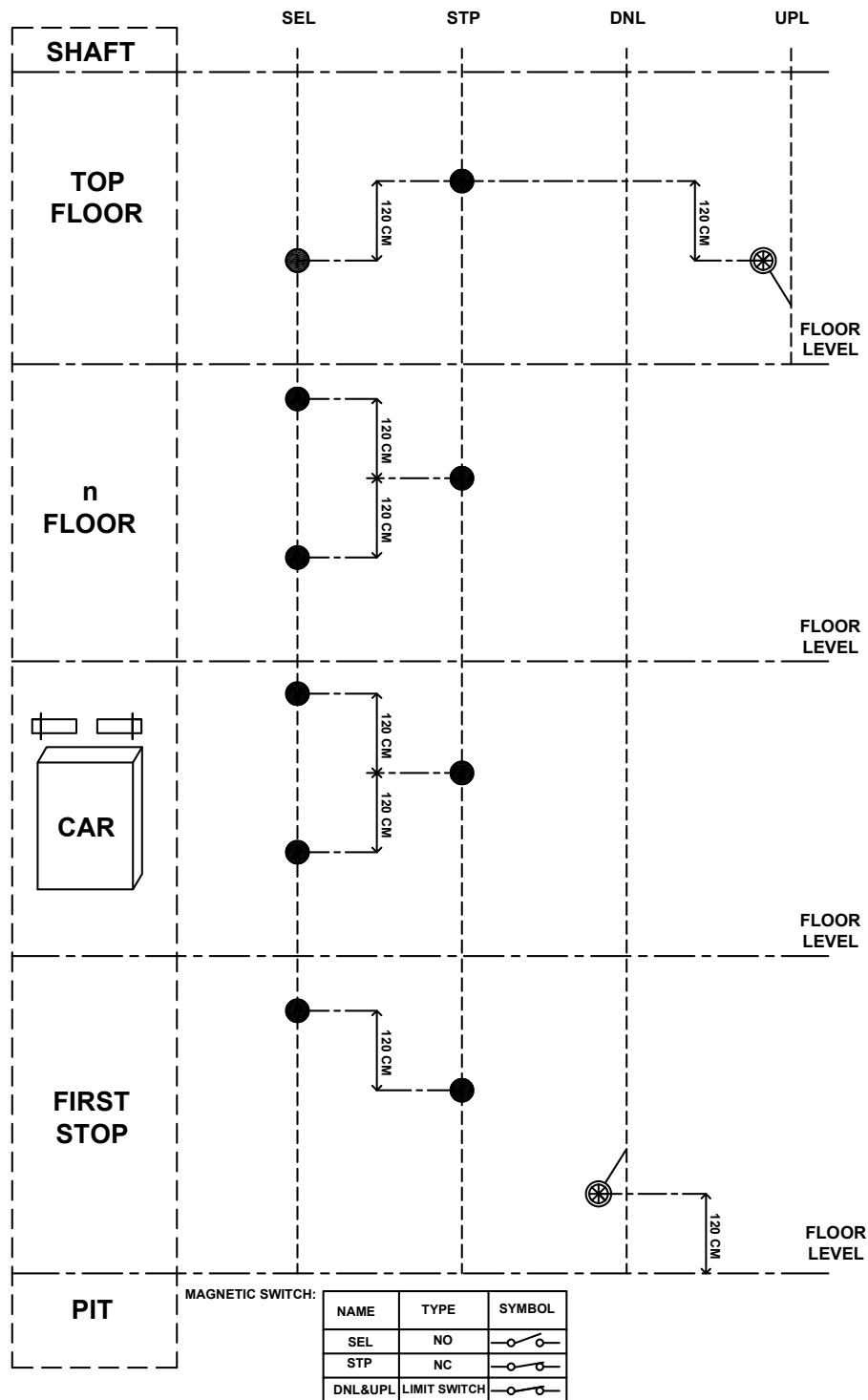

Figure 27.0 - Magnetic Configuration

### 3.21 Car

The terminals of the Car are connected as illustrated in Figure 28.0.

- Figure 28.0 illustrates the connection of the traveling cable terminals between the main control panel and the car for calls, indicators, inspection box, etc.

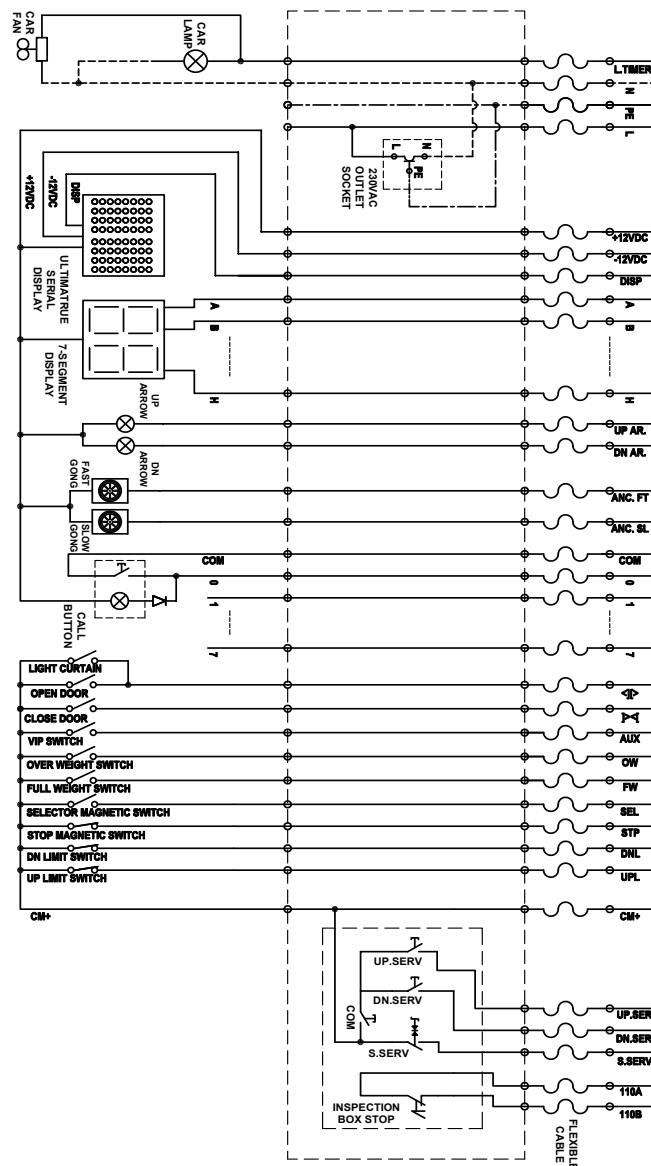

Figure 28.0 - Car Connections

## 4.0 Basic Programming

### Programming Mode Guide

The programming mode is operated using four push buttons on the XC-DUP series board.

- Reset: For entering and exiting the programming mode.
- Enter: For entering the programming mode or the programming steps, modification, and saving.
- (-) and (+) : Moving between programming steps.

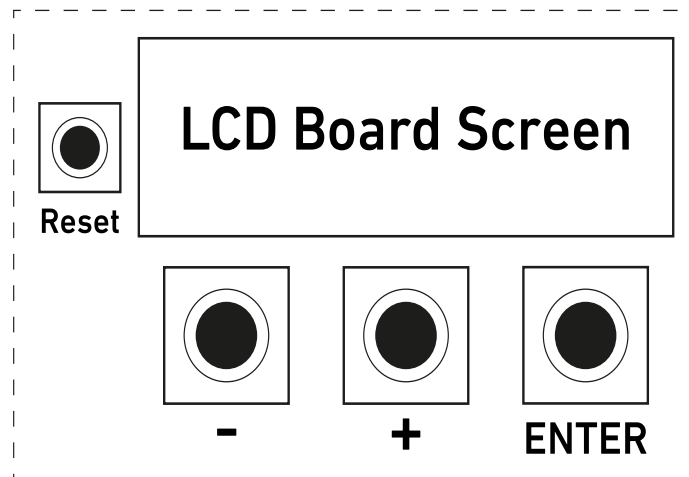

Figure 29.0 - Programming Guide Layout

## Basic Programs Login

Press the RESET button for two seconds, and then press and hold ENTER during the appearance of the welcome message. The second line contains production and version information.

```
ULTIMATRUE  
XC-D  
Y21M5-V7.34
```

When the next screen appears, release the ENTER button then Press (+) button to go to the password screen:

```
Press (+) key
```

Enter the password using (+) or (-) buttons. To go to the next digit, press ENTER.

```
Enter Password  
00000
```

Note:

The factory setting password is (00000).

After entering the correct password and pressing ENTER, the user will be directed to the basic program mode.

## 4.1 Program P1: Floor Number

This program is used to determine the number of active stops (doors).

- The number of active doors can be determined up to 16 stops (doors).
- Press ENTER to access this program or (+ or -) to select another program.
- After accessing this program, press (+ or -) to determine the number of stops, and then press ENTER after selection for saving. Stop numbers start from zero, thus for programming 8 stops select 7, and for programming 16 stops select 15.

P1 > Floor Number Floor No: 7
----------------------------------

## 4.2 Program P2: Display Mode

This program is used to determine the type of Indicator used from points A-to-H.

Press ENTER to access this program or (+ or -) to select another program.

After accessing the program, press (+ or -) to select the suitable display mode. In case of selecting 7-segment or binary indicator mode, the stop coordination screen will appear, enabling the user to select the required number to be displayed when the car is at the floor.

Display:  
7SEGMENT

Display:  
Floor Wire

Display:  
Binary NEG

Display:  
Binary POS

**Note:**

The left side digit (tens) can be assigned value of 'none' or '1', while the right side digit (units) can be assigned values ranging from these characters '0', '1', '2', '3', '4', '5', '6', '7', '8', '9', 'F', 'G', 'P', '-' or 'space'.

The program sequence is as follows:

- Press (+) or (-) to change the left digit.

Floor 0 : 0

- Press ENTER to go to the right digit.
- Press (+) or (-) to change the right digit.
- When finished, press ENTER and a 'Store' message will appear temporarily.
- Press ENTER again to save the number and go to the next stop (floor) or (+ or -) if you want to readjust the same stop (floor).
- Repeat the previous steps, until all stops (floors) are assigned the required display pattern.



### 4.3 Program P3: LED Matrix (XD-S)

This program is used to assign the required two-character alphanumeric combination for each stop that will be used with the RS232 serial indicator.

Note:

Only Ultimatrue Engineering Industries' elevator control Serial Indicators (XD-S) can be used.

- Press ENTER to access this program or (+ or -) to select another program.
- When using the serial indicator, complete ASCII printable characters are available for assignment to each of the two digits thus offering a very big symbol/character combination for any stop.
- After accessing the program, press (+ or -) to adjust each digit location as follows:

Floor 0 : 0

- Press (+) or (-) to change the left digit.
- Press ENTER to go to the right digit.
- Press (+) or (-) to change the right digit.
- When finished, press ENTER and a 'Store' message will appear temporarily.

- Press ENTER again to save the number and to go to the next stop or (+ or -) if you want to readjust the same stop.
- Repeat the previous steps, until all stops are assigned the required display pattern.

#### 4.4 Program P4: Door Type

This program is used to select the suitable door type.

- Press ENTER to access this program or (+ or -) to select another program

Door: Manual

Door: Semi-Auto

Door: Wait - Close

Door: Wait - Open

- After accessing this program, press (+ or -) to select the suitable door type.
- When finished, press ENTER to save and to go to the next program.

## 4.5 Program P5: System Type

This program is used to select the suitable system type.

- Press ENTER to access this program or (+ or -) to select another program.
- After accessing this program press (+ or -) to select the used system type.

-For XC-DUP-GL Series

System: Two Speed

System: Three Speed

-For XC-DUP-8 Series

System: One Speed

System: Two Speed

System: Hydraulic

- When finished, press ENTER to save and to go to the next program.

Note:

When the multi-speed inverter is operated, the two-speed system will be selected (XC-DUP-8).

- In the case of selecting the Hydraulic system, the user will be directed to another screen to enter the time in seconds of conversion from Star to Delta.

Star Time: 2

- By pressing ENTER, press (+ or -) to select the inspection speed.

Hyd Serv  
Fast

- By pressing ENTER you will go to the <Relevel> step selection to return the car to the designated stop level, in case of car reduction from stop level.
- Press (+ or -) to select the mode ON or OFF.

Re Level:  
0 OFF

Re Level:  
1 ON

- When finished, press ENTER to save and to go to the next program.

#### 4.6 Program P6: Collective

This program is used to select the method of serving landing calls.

- Press ENTER to access this program or (+ or -) to select another program.

Collective: Duplex.
------------------------

- When finished, press ENTER to save and to go to the next program.

## 4.7 Program P7: Wait Time

This program adjusts the time that the car will wait when arriving at a stop before moving again to serve the next call.

- Press ENTER to access this program or (+ or -) to select another program.
- After accessing this program, press (+ or -) to set the required time from 2-to-30 seconds.

Wait Time: 4

- When finished, press ENTER to save and to go to the next program.



#### 4.8 Program P8: CAM Time

This program adjusts the waiting time from the beginning of the CAM relay on the board working till lock closure.

- Press ENTER to access this program or (+ or -) to select another program.
- After accessing this program, press (+ or -) to set the required time from 2-to-10 seconds for manual doors.

CAM Time: 3

Note:

For automatic doors, the user can select different periods of time for opening and closing the door.

CAM Open: 3

CAM Close: 3

- When finished, press ENTER to save and to go to the next program.

#### 4.9 Program P9: Slow Time

This program adjusts the maximum time for moving the car with the SLOW speed, after which the car will automatically halt.

- Press ENTER to access this program or (+ or -) to select another program.
- After accessing this program, press (+ or -) to set the required time from 4-to-25 seconds.

Slow Time: 8

- When finished, press ENTER to save and to go to the next program.

## 4.10 Program P10: Fast Time

This program adjusts the maximum time for moving the car with the FAST speed, after which the car will automatically halt.

Note:

In case of the unavailability of a selector and floor-level pulses, the Fast Time program will trigger an event to stop the motor and XC-DUP series operations until the issue is resolved. In case of the availability of floor level pulses only, the car will continue moving in the same direction until it reaches the upper or lower limit switch, then moves at the SLOW speed, then stops at the floor level. This scenario ensures the safe evacuation of passengers in all Fast Time events.

- Press ENTER to access this program or (+ or -) to select another program.
- After accessing this program, press (+ or -) to set the required time from 10-to-90 seconds.

Fast Time: 15

- By pressing ENTER you will go to the supervisor step selection to specify how to get back to the normal mode of operation in case of a Fast Time Error.
- Press (+ or -) to select the mode ON or OFF.

- The supervisor mode ON will keep the XC-DUP series out of function displaying Fast Time Error even if the control board is reset, while supervisor mode is OFF normal operations of the XC-DUP series board are present when reset.
- To quit the supervisor mode ON and return to normal mode of operation, the XC-DUP series must enter the Inspection Mode and exit it.
- This action ensures that a qualified person supervises the cause of the Fast Time Error before the elevator is back to normal operations again.
- When finished, press ENTER to save and to go to the next program.

### 4.11 Program P11: Lamp Time

This program adjusts the time for the car light.

- Press ENTER to access this program or (+ or -) to select another program.
- After accessing this program press (+ or -) to set the required time from 1-to-90 seconds.

Lamp Time: 8

- When finished, press ENTER to save and to go to the next program.

## 4.12 Program P12: Three Phase Detection

### 4.12.1 Program P12: Phase Sequence

This program adjusts the selection between activation or deactivation of the phase sequence. The Three-Phase can be connected directly to the XC-DUP series without external components or circuitry. This program allows monitoring of the Three-Phase during operation and allows the elevator to operate normally at phase reversal without external additions; this program can be enabled or disabled through programming.

Note:

The feature is not present for hydraulic motors and (Phase Fail) or (Phase Sequence + Fail) can be chosen. In the case of using Three-Phase automatic doors, an external phase correction board is needed. **This program is only available for the XC-DUP-8 Sub-Series.**

- Press ENTER to access this program or (+ or -) to select another program.
- After accessing this program, press (+ or -) to select the mode ON or OFF.

Phase SEQ/FAIL:  
0 OFF

Phase SEQ/FAIL:  
1 ON

- When finished, press ENTER to save and to go to the next program

### 4.12.2 Program P12: Emergency

This program adjusts the preference of using built-in emergency actions that will control the inverter in case of power failure.

Note:

**This program is only available for the XC-DUP-GL Sub-Series.**

- Press ENTER to access this program or (+ or -) to select another program.
- After accessing this program, press (+ or -) to select the mode ON or OFF.

Emergency:  
0 OFF

Emergency:  
1 ON

- After Selecting the ON mode, press ENTER to set the time which the board waits after the power is OFF and start to turn on the RN relay. Press (+) or (-) to set this time from 4-to-50 seconds.

Rn: 5

- When finished, press ENTER to set the time between operating the RN relay and the start of the emergency signal. Press (+) or (-) to set the time from 1-to-20 seconds.

EMR Time: 2

- When finished, press ENTER to set the time between operating the emergency signal and starting to operate the UP direction signal, press (+) or (-) to set this time from 0-to-20 seconds.

EMR: 2

- When finished, press ENTER to save and to go to the next program



### 4.13 Program P13: Keycode

This program adjusts the preference of using the built-in COP (Car Operating Panel) as a three-digit access code entry keypad. The selected code sequence should be selected within the range of operating car calls terminals on the XC-DUP series.

- Press ENTER to access this program or (+ or -) to select another program.
- After accessing this program, press (+ or -) to select the mode ON or OFF.

KeyCode  
0 OFF

KeyCode  
1 ON

- When selecting the ON mode, you will be directed to a screen to adjust the required access sequence.

SET KEY CODE  
<<123>>

- Press (+ or -) to change the first digit, and then press ENTER to move and adjust the second and third digits.
- When finished, press ENTER to save and to go to the next program.

## 5.0 Advanced Programming

### Advanced Programs Login

Press the RESET button for two seconds, then press and hold ENTER during the appearance of the welcome message. The second line contains production and version information.

```
ULTIMATRUE  
XC-D  
Y21M5-V7.34
```

When the next screen appears, release the ENTER button then Press and hold (-) button then press the (+) button to go to the password screen:

```
PRESS (+) KEY
```

Enter the password using (+) or (-) buttons. To go to the next digit, press ENTER.

Note:

The factory setting password is (00000).

ENTER  
PASSWORD  
00000

- After entering the correct password and pressing ENTER, the user will be directed to the advanced program mode.

## 5.1 Program P14: CAM Trials

This program adjusts the number of CAM trials after which the control board will suspend operation. Selecting '0' means that the control board will drop all calls after the default CAM action and the control board can accept re-registering calls and repeating the CAM action indefinitely.

### Note:

In case the CAM fails to close the lock with the number of defined programmed trials, all calls are canceled to protect the CAM from overheating or damage.

- Press ENTER to access this program or (+ or -) to select another program
- After accessing this program, press (+ or -) to set the required CAM trials from 0-to-10 times.

CAM Trials: 0

- When finished, press ENTER to save and to go to the next program.

## 5.2 Program P15: Fork Time

This program adjusts the time duration where the elevator remains idle and there are registered calls and the door contact is open. After this time, all calls are canceled.

### Note:

Fork Time for manual doors, the time range is from 1-to-4 minutes, after the time has elapsed, the controller will cancel all calls, in case of failure of the manual door's close-contact (Floor). Fork Time for automatic doors, the door contact (fork) is used as an auxiliary lock point for the internal automatic door. It is recommended to connect it to the CM+ terminal if it's not intended to be used.

- Press ENTER to access this program or (+ or -) to select another program.
- After accessing this program, press (+ or -) to set the required time from 1-to-4 minutes.

Fork Time: 4

- When finished, press ENTER to save and to go to the next program.

### 5.3 Program P16: Park Time

This program adjusts the period of time during which the elevator remains idle with no registered calls (Park Time). After this period, the elevator will automatically move to a preset parking stop (Park Floor). To cancel this feature, adjust the park time to a value greater than 29 minutes, the screen will display a '0 OFF' message.

- Press ENTER to access this program or (+ or -) to select another program.
- After accessing this program press (+ or -) to set the required time from 1-to-29 minutes.

Park Time: 4  
1 ON

- Press ENTER to save and go to the next screen, through which the parking stop (floor) is determined.

Park Floor: 0

- When finished, press ENTER to save and to go to the next program.

## 5.4 Program P17: Operation Timeout

This program adjusts the period of time after which the XC-DUP series will stop working. This function is useful for forced routine maintenance checks. The period can be adjusted from 1-to-6 months.

- Press ENTER to access this program or (+ or -) to select another program.
- After accessing this program, press (+ or -) to set the required parameter.
- OFF: The XC-DUP series will operate indefinitely.

```
Oper.Timeout:  
0 OFF
```

- ON: The XC-DUP series will operate for the defined period.

```
Oper.Timeout:  
1 ON
```

- The ON selection will initiate the period screen to adjust the operation period from 1-to-6 months.

```
Period:  
1 Month
```

- RESTART: The operation time will be reset and disabled.

Oper.Timeout:  
2 Restart

- When finished, press ENTER to save and to go to the next program.



## 5.5 Program P18: Service Telephone

This program adjusts the service company telephone number so that it can be displayed on the LCD board screen in case of operation period timeout which stops the elevator from working.

- Press ENTER to access this program or (+ or -) to select another program.
- After accessing this program, press (+ or -) to set the required telephone digit by digit.

Service Tel.  
000000000000

- When finished, press ENTER to save and to go to the next program.

## 5.6 Program P19: Set Password

This program enables you to change the password to log on into the two programming modes.

- Press ENTER to access this program or (+ or -) to select another program.
- After accessing this program, press (+ or -) to set the first digit of the basic password.

Basic Password  
>>00000<<

- Press ENTER to move to the next digit and adjust it.
- Repeat the same sequence for the five digits.
- Press ENTER to save and go to advanced password settings.

Advanced Password  
>>00000<<

- Enter the required password in the same manner of the basic password.
- When finished, press ENTER to save and to go to the next program

## 5.7 Program P20: Active Floor

This program can enable or disable every landing or car call button independently. This function is useful for intentionally making certain floor(s) out of service. 'EXTERNAL' stands for landing calls while 'INTERNAL' stands for car calls.

### Note:

The Active Floor program facilitates maximum programming control, in which excluding a stop (internally, externally, or both) is set using the Active Floor programming mode, without the necessity of removing the elevator stops' wiring from the XC-DUP series.

- Press ENTER to access this program or (+ or -) to select another program.
- After accessing this program, press (+ or -) to set the required parameter as preferred.
- OFF: The indicated stop (floor) number call button will be disabled internally or externally.

Floor 0: External 0 OFF
----------------------------

- ON: The indicated stop (floor) number call button will be enabled internally or externally.

Floor 0: External  
1 ON

- After choosing, press ENTER then press (+ and -) together to confirm selection.

Floor 0: External  
Press code

- When finished, press ENTER to save and to go to the next program.

## 5.8 Program P21: Lock Error

This program can enable or disable the lock error function. This program is useful for continuously monitoring the lock contact during each call served at any stop. This feature is supposed to ensure the safety of the door lock when activated. In this sense, it is necessary to open the lock contact every time the car stops on the floor. In case of not opening the lock contact, the car will not move to ensure passenger's safety.

- Press ENTER to access this program or (+ or -) to select another program.
- After accessing this program, press (+ or -) to set the required parameter as preferred.

Lock Error:  
0 OFF

Lock Error:  
1 ON

- After choosing, press ENTER then press (+ and -) together to confirm selection.

Lock Error:  
Press Code

- When finished, press ENTER to save and to go to the next program.

## 5.9 Program P22: Max Calls

This program can select the maximum number of car calls that can be registered at a time. This feature is supposed to secure the elevator from any abnormal passenger behavior, where the registration of car calls greater than the preset Maximum Calls will not be accepted.

- Press ENTER to access this program or (+ or -) to select another program.
- After accessing this program, press (+ or -) to set the required parameter as preferred.

Max Calls:  
0 OFF

Max Calls:  
4 Calls

- After choosing, press ENTER then press (+ and -) together to confirm selection.

Max Calls:  
Press Code

- When finished, press ENTER to save and to go to the next program.

## 5.10 Program P23: Fire Man

This program can enable/disable the fireman actions taken in case of fire alarm signals. The Fire Floor is the default stop that the elevator automatically will go to in case of fire.

- Press ENTER to access this program or (+ or -) to select another program.
- After accessing this program, press (+ or -) to set the required parameter as preferred.

Fire Man:  
0 OFF

Fire Man:  
1 ON

- After choosing the ON mode, press ENTER then press (+ and -) together to confirm selection.
- Then the screen determining the Fire Floor will be displayed.

Fire Man:  
Press Code

Fire Floor: 0

- Press (+ or -) to determine or set the required floor as preferred.
- When finished, press ENTER to save and to go to the next program.



### 5.11 Program P24: Factory Set

This program is used to restore all the XC-DUP series settings to its factory defaults.

- Press ENTER to access this program or (+ or -) to select another program.

Factory Set:  
Press Code

- After accessing this program, press (+ and -) together to confirm selection.

Factory Set: OK

- When finished, press ENTER to save and to go to the next program.

## 5.12 Program P25: Restore Selector

This program is supposed to correct the selector counter by going to the ground floor every time the power is OFF and back ON again.

- Press ENTER to access this program or (+ or -) to select another program.
- After accessing this program, press (+ or -) to select the mode ON or OFF.

Restore Selector: 0 OFF
----------------------------

Restore Selector: 1 ON
---------------------------

- When finished, press ENTER to save and to go to the next program.

### 5.13 Program P26: Service Control (Inspection Mode)

This program enables the operator to control the elevator in inspection mode using programming buttons, so that the (+) button is used to move the car in the UP direction, the (-) button is used to move the car in the DOWN direction, the ENTER button to switch the speed of the elevator before moving the car, and the RESET button is used to exit this mode.

Note:

There exists an interlock between the activation of the Service Control (Inspection Mode) program and the inspection signal from the shaft to prioritize maximum safety for the technician.

#### 5.13.1 Program P26 : Service Control (XC-DUP-8)

- Press ENTER to access this program or (+ or -) to select another program.
- After accessing this program, press (+) to activate this program, and press ENTER to confirm the selection.

Manual Service: 1 OFF
--------------------------

Manual Service: 1 ON
-------------------------

- The following screen will appear through which the elevator motion speed can be selected between FAST or SLOW in this mode.
- Press ENTER to switch the speed of the elevator before moving the car.

F2 S4 SLOW:  
ERR: SERV 8

F2 S4 FAST:  
ERR: SERV 8

- For moving the car, (+) or (-) buttons are used according to the desired direction.
- When finished, press ENTER to save and to go to the next program.

### 5.13.2 Program P26 : Service Control (XC-DUP-GL)

-For program activation, press the ENTER and the (+) buttons together during normal mode. This mode is activated without the need of accessing the programming tutorial.

- For moving the car, (+) or (-) buttons are used according to the desired direction.
- When finished, press ENTER to save and to go to the next program.

**6.0 Additional Programming**

**6.1 Binary Indicator (XD-B)**

Programming Values	Displayed Symbols on Binary Indicator (XD-B)
0	BLANK
1	P1
2	G
3	M
4	1
5	2
6	3
7	4
8	5
9	6
10	7
11	8
12	9
13	10
14	11
15	12
16	13
17	14
18	15
19	16

**Table 11.0 - Binary Indicator (XD-B) Programming**

## 7.0 Malfunction Diagnosis

### 7.1 LCD Board Screen

As an advantage of the XC-DUP series, faults and errors can be viewed on the LCD board screen in both error codes and notations.

Error Code	Error Notation	Description
1	SLIP	Over Travel Error
2	MTR	Motor Over Current Error
3	UPLM	UP Limit Error
4	DNLM	DOWN Limit Error
5	S-F, S-L	Safe Fork and Safe Lock
6	FORK	Manual Door Contact Error
7	LOCK	Door Lock Contact Error
8	SERV	Inspection Mode
9	STOP	Car Stop
10	FIRE	Fire Alarm
11	RESERVED	---
12	FSTT	Fast Time Error
13	O.WT	Overweight
14	PHFL	Phase Fail Error
15	EMER	Emergency
	*	Short Circuit On The Call Push Button

Table 12.0 - LCD Board Screen Error View

## 7.2 7-Segment Indicator

Error Notation	Description
E	Open UP or Down Limit
L	Safe Lock
C	Car Stop
H	Phase Fail Error
F	Fast Time Error
U	Fork Time Error
n	MTR (Motor Overload)
≡	Slip, Inspection Mode, and Overweight

Table 13.0 - 7-Segment Indicator Error View

## 8.0 Disclaimer

The manufacturer shall have no obligation for damage, injury, or any legal responsibility incurred directly or indirectly from the use of any of the products. The user shall observe safe and lawful practices including, but not limited to, those set forth in this document. Should further information be desired or should particular obstacles arise which are not specifically covered for the client's purposes, the matter should be referred to Ultimatrue Engineering Industries.

Ultimatrue Engineering Industries reserves the right to make technical changes or modify the contents of this document without prior notification. With regard to purchase orders, the agreed particulars shall prevail. Ultimatrue Engineering Industries does not accept any responsibility for possible lack of information in this document.

Ultimatrue Engineering Industries reserves all rights in this document and in the subject matter and illustrations contained therein. Any reproduction, disclosure to third parties, or utilization of its content - in whole or in part - is forbidden without prior consent of Ultimatrue Engineering Industries.

© Copyright 2023 Ultimatrue Engineering Industries.

All rights reserved.



## 9.0 Warranty

Ultimatrue Engineering Industries warrants the XC-DUP series board against all manufacturing defects for a period of one year after the date of installation and operation, provided that the user strictly adheres to all technical specifications and instructions illustrated in the user manual. The warranty is not valid in the following cases:

- Defects caused by failures or mistakes in the XC-DUP series board connections or wiring.
- Defects caused by incorrect introduction of high or low voltage.
- Defects caused by misuse and non-compliance with the illustrated operating instructions in the user manual.
- Defects caused by intended damages or fire.

---

**Index**

7-Segment Indicator 02, 04, 05,  
37, 110, 113

**A**

Active Floor, 98, 113

Advanced Programming, 03, 89,  
113

Automatic, 02, 05, 10, 12, 46, 47,  
48, 49, 113

**B**

Basic Programming, 02, 67, 113

Binary Indicator, 03, 108, 113

**C**

CAM, 03, 10, 12, 45, 47, 48, 58,  
59, 80, 91, 113

Control System, 18

**D**

Diagnosis, 04, 109, 113

**F**

Floor Wire Indicator, 02, 38, 39,  
113

Fork 92, 109, 110, 113

**H**

Hydraulic, 02, 05, 06, 10, 57, 60,  
61, 76, 113

**I**

Inspection, 01, 10, 12, 14, 83,  
106, 109, 110, 113

Inverter 02, 06, 12, 50, 51, 56,  
113

**M**

Manual, 1, 02, 16, 45, 48, 74,  
106, 109, 113

Motor 12, 16, 30, 57, 109, 110,  
113

**P**

Phase, 02, 03, 05, 06, 19, 46, 47,  
48, 49, 54, 55, 58, 85, 109, 110,  
113

**S**

Semi-Automatic, 02, 48, 49, 113

Shaft 01, 10, 12, 27, 28, 113

**X**

XD-2W, 07

XD-B, 03, 07, 108, 113

XDP-2W, 07

XD-S, 72, 113

XE-1, 07, 10, 12, 18, 38

---

**Ultimatrue Engineering Industries**

14 Obour Buildings, Salah Salem St.

11811 Cairo

Egypt

+20 102 366 6065

[info@ultimatrue.com](mailto:info@ultimatrue.com)

[www.ultimatrue.com](http://www.ultimatrue.com)

As standards, specifications, and design vary over periods of time, please ask for confirmation of the information provided in this publication.

© 2023 Copyright Ultimatrue Engineering Industries. All rights reserved.

XC-DUP Series - Version 2.0.

---